

FM - APPROVED RATINGS BHP & KW

ENGINE MODEL:	AF10-128
EMISSIONS:	TIER 0
DATE:	09/01/2020
DRAWING NUMBER:	AF10-128.00
PERFORMANCE CURVE NUMBER:	C010128F
RATED POWER:	617 BHP @ 2100 RPM 460 KW @ 2100 RPM
REFERENCE NUMBER:	14DS001E
VERSION:	A

GENERAL ENGINE DATA

TYPE:	4 CYCLE; V-TYPE; WATER COOLED	
NUMBER OF CYLINDERS:	10	
ASPIRATION:	TURBOCHARGED + WATER COOLED	
BORE & STROKE - IN [MM]:	5.04 x 5.59 [128 x 142]	
CYLINDER LINER TYPE:	<input checked="" type="checkbox"/> WET <input type="checkbox"/> DRY	
DISPLACEMENT - IN ³ [L]:	1115 [18.27]	
COMPRESSION RATIO:	14.6:01	
FIRING ORDER:	1 - 6 - 5 - 10 - 2 - 7 - 8 - 3 - 4 - 9	
COMBUSTION SYSTEM:	DIRECT INJECTION	
ROTATION (AS VIEWED FROM FRONT OF ENGINE):	CCW	
VALVES PER CYLINDER:	INTAKE: 1 EXHAUST: 1	
VALVE LASH (COLD ENGINE):	INTAKE - IN [MM]:	0.010 [0.25]
	EXHAUST - IN [MM]:	0.014 [0.35]
IGNITION TYPE:	COMPRESSION (DIESEL)	
CHARGE AIR COOLING TYPE:	RAW WATER	
WEIGHT (FUEL PUMP CONFIGURATION) - LBS [KG]:	3605 [1635]	
DIMENSIONS (L x W x H) - IN [MM]:	67 x 53 x 72 [1710 x 1355 x 1830]	
FLYWHEEL / FLYWHEEL HOUSING DIMENSIONS:	14.00 / SAE #1	
TORQUE @ RATED RPM - LB-FT [N-M]:	1543 [2092]	

ENGINE PERFORMANCE DATA

ESTIMATED FREE FIELD SOUND PRESSURE LEVEL AT 3 FEET [1 METER] WITH FULL-LOAD GOVERNED SPEED (INCLUDES NOISE FROM EXHAUST, COOLING SYSTEM AND DRIVEN COMPONENTS)	dBa	≤ 107
ALL DATA IS BASED ON ENGINE OPERATING WITH FUEL SYSTEM, LUBRICATING OIL PUMP, AIR CLEANER AND ALTERNATOR. DOES NOT INCLUDE AIR COMPRESSOR, FAN & OPTIONAL EQUIPMENT. DATA IS BASED ON SAE STANDARD J1349 CONDITIONS AT 300 FEET [91.4 METERS] ALTITUDE, 29.61 INCHES [752 MILLIMETERS] HG DRY BAROMETER AND 77°F [25°C] INTAKE AIR TEMPERATURE USING #0 DIESEL FUEL FOLLOWING THE GB 252-2011 STANDARD.		
ALTITUDE ABOVE WHICH OUTPUT SHOULD BE DERATED:	FEET [METER]	300 [91]
DERATE PER 1,000 FEET [305 METERS] ABOVE ALTITUDE LIMIT:	3%	
TEMPERATURE ABOVE WHICH OUTPUT SHOULD BE DERATED:	°F [°C]	77 [25]
DERATE PER 10°F [5.6°C] ABOVE TEMPERATURE LIMIT:	1%	

● ALL DATA CERTIFIED WITHIN ±5%.

EXHAUST SYSTEM

EXHAUST GAS TEMPERATURE @ MAXIMUM RATING (POWER) - °F [°C]:	≤ 1002 [539]
EXHAUST GAS FLOW @ MAXIMUM OUTPUT - CFM [M ³ /HR]:	3581 [6084]
MAXIMUM ALLOWABLE BACK PRESSURE - PSI [KPA]:	1.45 [10]
MINIMUM EXHAUST PIPE DIAMETER - IN [MM]:	4 [100]

AIR INTAKE SYSTEM

AIR CLEANER TYPE:	DRY TYPE, DISPOSABLE
AIR FLOW - CFM [M ³ /HR]:	2133 [3624]
AIR INLET RESTRICTION (DIRTY) - PSI [KPA]:	≤ 0.87 [6]
AIR INLET RESTRICTION (CLEAN) - PSI [KPA]:	≤ 0.29 [2]

LUBRICATION SYSTEM

OIL CAPACITY (ENGINE ONLY) - QTS [L]:	37.0 [35]
MAXIMUM SUMP OIL TEMPERATURE - °F [°C]:	248 [120]
NORMAL OPERATING OIL PRESSURE RANGE - PSI [BAR]:	43.5 ~ 58.0 [3.0 ~ 4.0]
OIL PRESSURE @ IDLE - PSI [BAR]:	> 14.5 [1.0]

COOLING SYSTEM

COOLANT CAPACITY (ENGINE & HEAT EXCHANGER) - QTS [L]:	54.9 [52]	
THERMOSTAT RANGE:	START OPEN - °F [°C]:	160 [71]
	FULL OPEN - °F [°C]:	185 [85]
COOLANT PRESSURE MAXIMUM - PSI [BAR]:	13 [0.9]	
MAXIMUM ENGINE COOLANT TEMPERATURE - °F [°C]:	≤ 208 [98]	
ENGINE COOLANT FLOW @ FULL SPEED - GPM [M ³ /HR]:	185 [42]	
RAW WATER COOLING CAPACITY - GPM [M ³ /HR]:	114 [26]	
RAW WATER PRESSURE - PSI [BAR]:	29 [2.0]	
MAXIMUM RAW WATER TEMPERATURE - °F [°C]:	100 [37.8]	
RAW WATER INTAKE PIPE SIZE:	RAW WATER INLET - IN:	1.50 NPT
	RAW WATER OUTLET - IN:	2.00 NPT

HEATER SYSTEM

WATTAGE - W:	4500
VOLTAGE (AC) - V:	220

DC ELECTRICAL SYSTEM

NORMAL SYSTEM VOLTAGE - V:	24
STARTER MOTOR - HP [KW]:	9.4 [7.0]
RECOMMENDED BATTERY SIZE - AH:	200
COLD CRANKING AMPS @ 0°F (-18°C):	1000
RESERVE CAPACITY - AMPS:	407
CHARGING ALTERNATOR OUTPUT - AMPS:	45
STARTER CRANKING AMPS, ROLLING @ 0°F (-18°C):	510
MINIMUM CRANKING SPEED REQUIRED FOR UNAIDED COLD START - RPM:	180

● ALL DATA CERTIFIED WITHIN ±5%.

FUEL SYSTEM

INJECTION PUMP:	V-TYPE, PLUNGER TYPE
INJECTION PUMP ADVANCE ANGLE - °:	16
MINIMUM SUPPLY LINE SIZE - IN [MM]:	0.50 [12]
MINIMUM RETURN LINE SIZE - IN [MM]:	0.50 [12]
FUEL MANAGEMENT CONTROL:	MECHANICAL
FUEL CONSUMPTION @ 2100 RPM - LB/BHP-HR [G/KW-HR]:	0.368 [224]
IDLE SPEED - RPM:	750
MAXIMUM GOVERNED SPEED - RPM:	2310
MAXIMUM ALLOWABLE FUEL HEIGHT ABOVE FUEL PUMP - FT [M]:	9.8 [3]
GOVERNED SPEED RATE - %:	≤ 10

① ALL DATA CERTIFIED WITHIN ±5%.



ENGINE MATERIALS & CONSTRUCTION

ENGINE		AIR INTAKE	
CAMSHAFT:		AIR CLEANER:	
TYPE	OVERHEAD	TYPE	DRIP PROOF
MATERIAL	CARBON STEEL	MATERIAL	PLEATED PAPER
LOCATION	IN BLOCK	COOLING SYSTEM	
DRIVE	SPUR GEAR	COOLANT HEAT EXCHANGER:	
CONNECTING RODS:		TYPE	TUBE & SHELL
TYPE	I-BEAM, FRACTURE	MATERIAL	
MATERIAL	FORGED STEEL	ELECTRODE	ZINC
CRANKSHAFT:		HEADERS	ALUMINUM
TYPE	GROUND	SHELL	ALUMINUM
MATERIAL	DUCTILE IRON	TUBES	COPPER
MAIN BEARINGS:		COOLANT PUMP:	
TYPE	PRECISION, HALF SHELL	TYPE	CENTRIFUGAL
MATERIAL	TIM ALUMINUM ALLOY	DRIVE	V-BELT
CYLINDER BLOCK:		THERMOSTAT:	
TYPE	GANTRY	TYPE	NON-BLOCKING
MATERIAL	CAST IRON	QUANTITY	1
CYLINDER HEAD:		COOLING LOOP (GALVANIZED):	
TYPE	ONE PIECE	TEES, ELBOWS, PIPE	GALVANIZED STEEL
MATERIAL	CAST IRON	BALL VALVES	BRASS
CYLINDER LINERS:		SOLENOID VALVE	BRASS
TYPE	WET LINED	PRESSURE REGULATOR	BRASS
MATERIAL	CAST IRON ALLOY	STRAINER	BRASS
PISTONS:		COOLING LOOP (316 STAINLESS STEEL):	
TYPE	TRUNK	TEES, ELBOWS, PIPE	316 STAINLESS STEEL
MATERIAL	ALUMINUM ALLOY	BALL VALVES	316 STAINLESS STEEL
PISTON PINS:		SOLENOID VALVE	316 STAINLESS STEEL
TYPE	FULL FLOATING	PRESSURE REGULATOR	316 STAINLESS STEEL
MATERIAL	ALLOY STEEL	STRAINER	316 STAINLESS STEEL
PISTON RINGS:		FUEL SYSTEM	
FIRST	DUCTILE CAST IRON	FUEL INJECTION PUMP:	
SECOND	ALLOY CAST IRON	TYPE	FULL MECHANICAL, CENTRIFUGAL
THIRD	ALLOY CAST IRON	DRIVE	GEAR DRIVEN
VALVES:		LUBRICATION SYSTEM	
TYPE	POPPET	TYPE	GEROTOR
ARRANGEMENT	OVERHEAD	DRIVE	GEAR
VALVE # PER CYLINDER	2 INTAKE, 2 EXHAUST		
OPERATING MECHANISM	MECHANICAL ROCKER ARM		
LIFTER TYPE	LARGE HEAD		

SPARE PARTS LIST

PART DESCRIPTION	PART NUMBER	REMARKS
AFTERCOOLER	AF1500073926	KL19
HEAT EXCHANGER	AFC900ZZ-HE	MAX. WORKING PRESSURE 72.5 PSI [5 BAR]
ALTERNATOR	300901-0075	28 V / 45 A
STARTING SYSTEM	300516-00075B	24 V / 7 KW
TURBOCHARGER	150105-00438A 150105-00439A	N/A
FUEL PUMP WITH SPEED CONTROLLER	65.11101-7334	N/A
FUEL INJECTORS	65.10102-6047	0.40 MM
CONTROLLER	AF.ENG.AB-ETS-R-B	N/A
BATTERY	908DFT	12 V / 200 AH
EMERGENCY STARTERS	535-0098	24 VDC 800 A
OIL PRESSURE SENSOR	KE21103	11.6 ± 4.35 PSI [80 ± 30 KPA]
HIGH TEMPERATURE COOLANT SENSOR	KE00102	203 ± 37 °F [95 ± 3°C]
LOW COOLANT TEMPERATURE SENSOR	KE00121	104 ± 37 °F [40 ± 3°C]
HIGH TEMPERATURE RAW WATER SENSOR	204.040.15GO.1.IP65	104 ± 37 °F [40 ± 3°C]
FLOW SENSOR	WK150B	N/A
OVERSPEED SHUTDOWN DEVICE	YC-ENL-A0	N/A
SPEED SENSOR	KE10050	N/A
ENGINE HEATER	FH220450065	220 V / 4.5 KW MAX. TEMP 149°F [65°C]
	SH110200065	220 V / 2 KW MAX. TEMP 149°F [65°C] WITH PUMP
	SH110200065	110 V / 2 KW MAX. TEMP 149°F [65°C] WITHOUT PUMP
OIL FILTERS	65.05510-5030B	2 PIECES
FUEL FILTERS	65.12503-5018A	2 PIECES
AIR FILTERS	400504-00169	2 PIECES
BELTS	130205-00305	2 PIECES
THERMOSTATS	300738-00159	3 PIECES
EXHAUST BLANKET	AF12128C0801-EI	DN100
FUEL SUPPLY & RETURN LINES	AF12-128-12.01 AF12-128-12.02	N/A

POWER CURVE

CURVE NUMBER:	C10128F	DATE:	09/01/2020
DISPLACEMENT - IN ³ [L]:	1115 [18.27]	ASPIRATION:	TURBOCHARGED + WATER COOLED
POWER STANDARD:	FM	BORE & STROKE - IN [MM]:	5.04 x 5.59 [128 x 142]
NUMBER OF CYLINDERS:	10	FUEL SYSTEM:	V-TYPE, MECHANICAL

● ALL DATA CERTIFIED WITHIN ±5%.

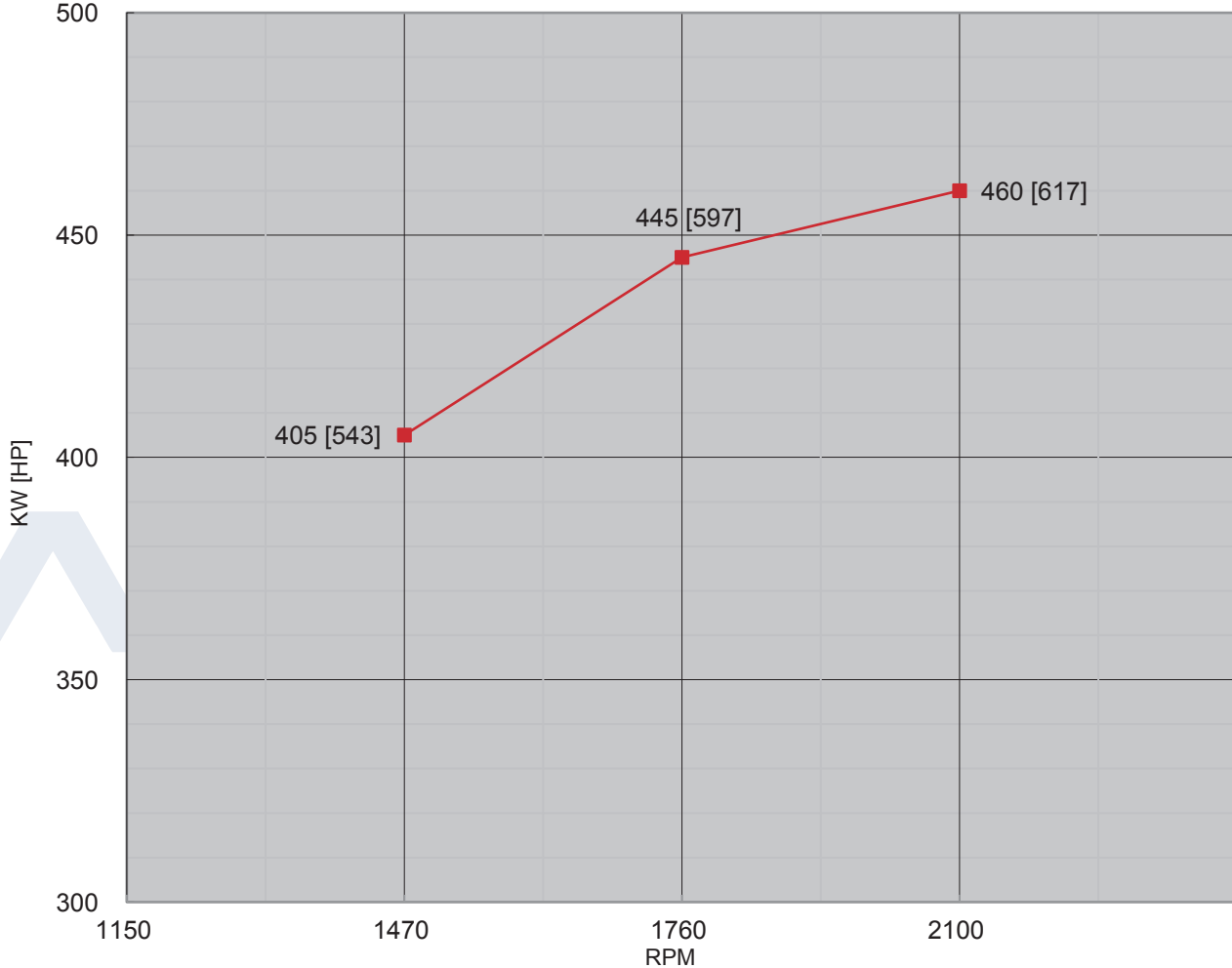

TORQUE		
SPEED	LB-FT	N-M
RPM		
1150		
1470	1938	2628
1760	1783	2417
2100	1543	2092

OUTPUT POWER		
SPEED	HP	KW
RPM		
1150		
1470	543	405
1760	597	445
2100	617	460

FUEL CONSUMPTION		
SPEED	LB/BHP-HR	G/KW-HR
RPM		
1150		
1470	0.327	199
1760	0.337	205
2100	0.368	224

● ALL DATA IS BASED ON ENGINE OPERATING WITH FUEL SYSTEM, LUBRICATING OIL PUMP, AIR CLEANER AND ALTERNATOR. DOES NOT INCLUDE AIR COMPRESSOR, FAN & OPTIONAL EQUIPMENT. DATA IS BASED ON SAE STANDARD J1394 CONDITIONS AT 300 FEET [91.4 METERS] ALTITUDE, 29.61 INCHES [752 MILLIMETERS] HG DRY BAROMETER AND 77°F [25°C] INTAKE AIR TEMPERATURE USING #0 DIESEL FUEL FOLLOWING THE GB 252-2011 STANDARD.

DATUMS:

- A - DIMENSIONAL FACE OF FLYWHEEL
- B - ENGINE HORIZONTAL CENTER (CRANKSHAFT)
- C - ENGINE VERTICAL CENTER (CRANKSHAFT)

NOTES:

1. FUEL SUPPLY PIPING MINIMUM INSIDE DIAMETER FROM TANK TO ENGINE MUST BE ≥ 0.512 [13].
2. FUEL RETURN PIPING MINIMUM INSIDE DIAMETER FROM TANK TO ENGINE MUST BE ≥ 0.512 [13].

DRAWING SUBJECT TO CHANGE WITHOUT NOTICE.

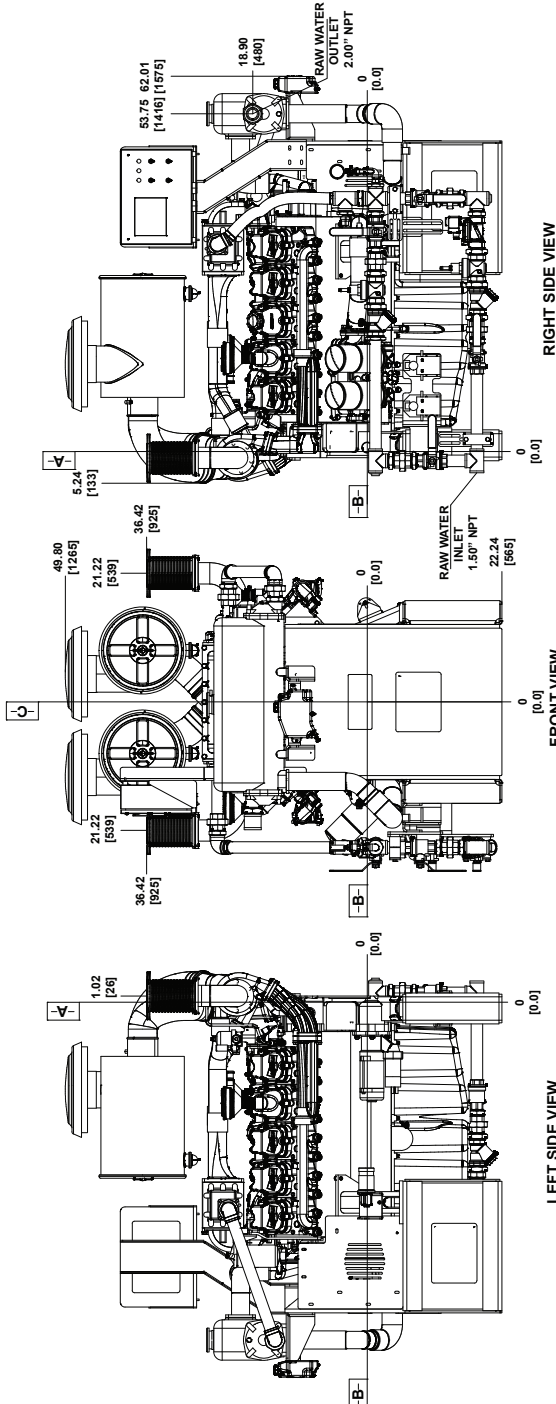

LEFT SIDE VIEW

FRONT VIEW

RIGHT SIDE VIEW

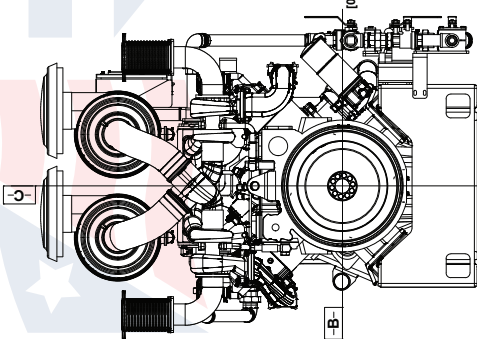

MOUNTING DIMENSIONS

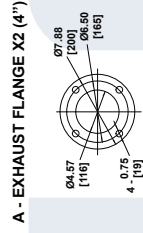

A - EXHAUST FLANGE X2 (4")

SCALE 2:1

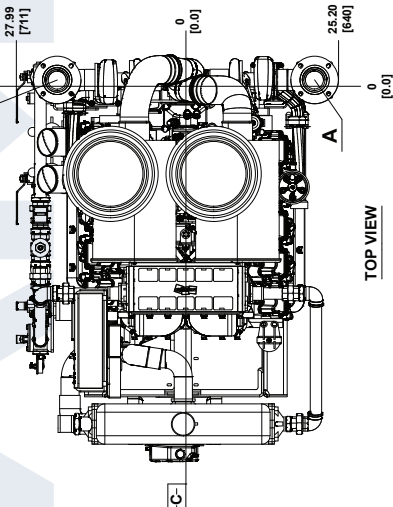

TOP VIEW

FLYWHEEL HOUSING SAE #1 FLYWHEEL 14.00

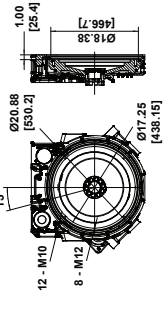

REV	UNITS	DESCRIPTION	DATE	DATE	DATE	DATE	DATE
A	IN/MM	CREATION	MJF	09/01/2020			
REV	IN/MM	DESCRIPTION					

DATE:	09/01/2020	NAME:	INSTALLATION DRAWING
CHK BY:		PROJECT:	DIESEL FIRE PUMP DRIVER
APPROVED:		MODEL:	AF10-128
		PART NO.:	AF10-128-00
		MATERIAL:	

SCALE:	NONE	PAGE:	1
OF	1		

NOTES:

1. ALL PLUMBING MUST BE SUPPORTED AND/OR ISOLATED SO THAT NO WEIGHT OR STRESS IS APPLIED TO ANY ENGINE COMPONENT.
2. REFER TO SPECIFIC MODELS' INSTALLATION, OPERATION & MAINTENANCE MANUAL FOR INSTALLATION GUIDELINES.

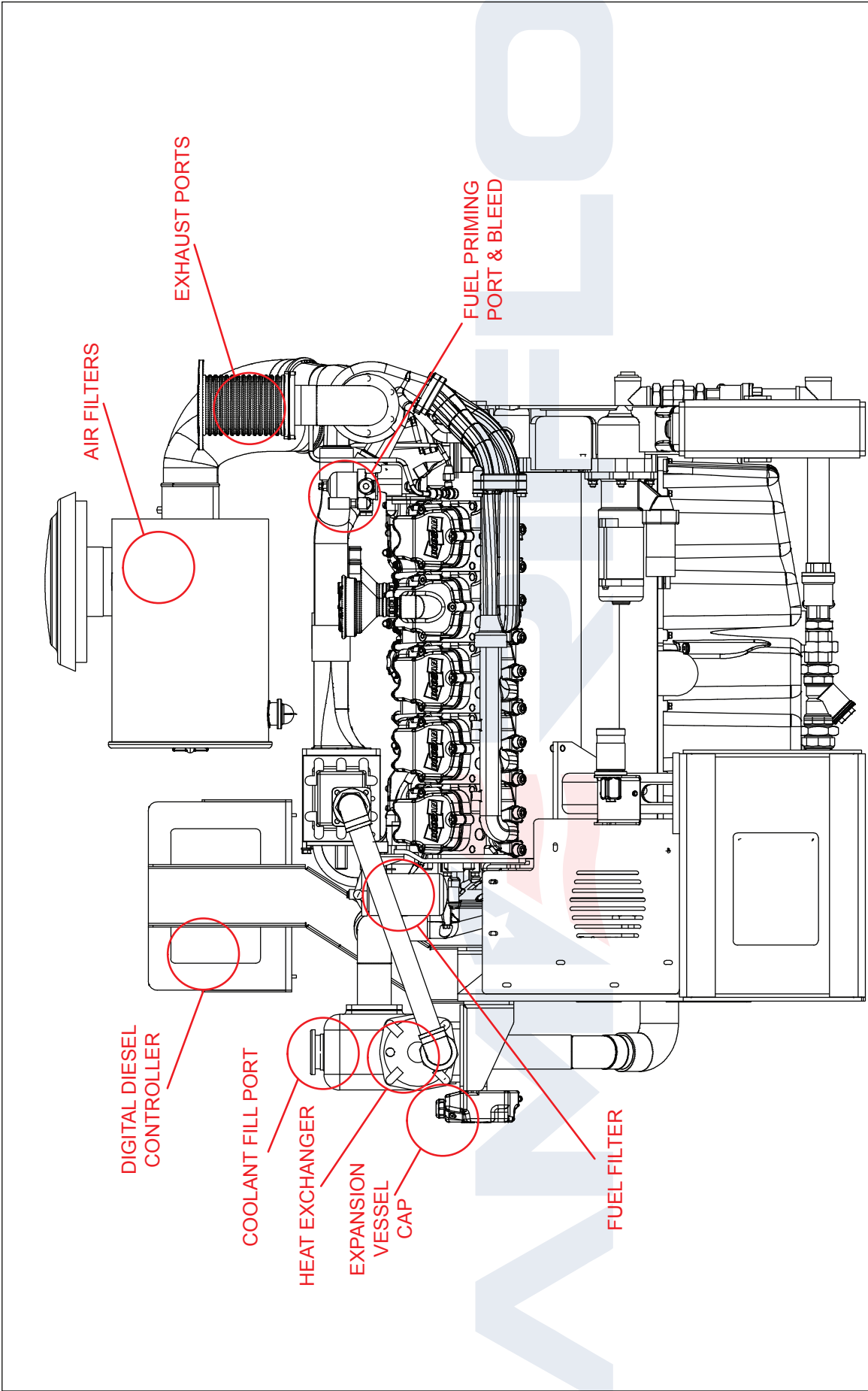

REV	UNITS	IN (MM)	PROJECTION:	PROJECT:
			1st Angle	
			SCALE: NONE	PAGE 1 OF 1
			APPROVED: DATE:	MATERIAL:
			09/01/2020	
			APVD	
			DWN	
			DESCRIPTION	
			CREATION	
			MJF	
			DATE	
			09/01/2020	
			CHK BY:	
			MJF	
			DATE:	
			09/01/2020	
			DATE:	
			09/01/2020	
			NAME:	
			INSTALLATION DRAWING	
			DIESEL FIRE PUMP DRIVER	
			MODEL AF10-128	
			PART NO.:	
			AF10-128-LEFT	

NOTES:

1. ALL PLUMBING MUST BE SUPPORTED AND/OR ISOLATED SO THAT NO WEIGHT OR STRESS IS APPLIED TO ANY ENGINE COMPONENT.
2. REFER TO SPECIFIC MODELS' INSTALLATION, OPERATION & MAINTENANCE MANUAL FOR INSTALLATION GUIDELINES.

