

AMERIFLO

9050 SERIES

AF12-128C DIESEL ENGINE

INSTALLATION, OPERATION & MAINTENANCE MANUAL

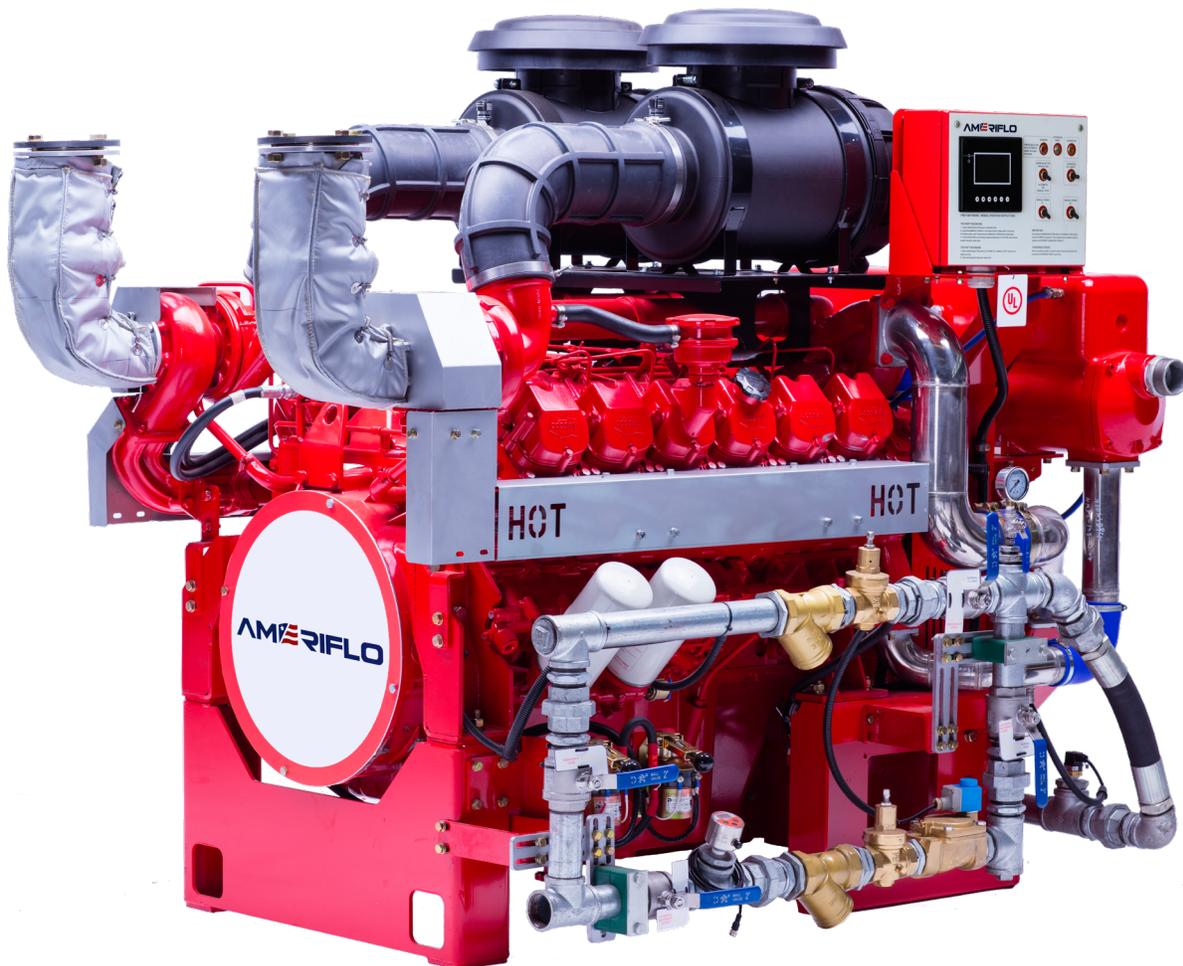

Table of Contents

- 4OVERVIEW
- 4SAFETY PRECAUTIONS
- 5PERSONNEL QUALIFICATION
- 5NON-COMPLIANCE
- 5INSPECTION & INSTALLATION
- 5UNAUTHORIZED MODIFICATION
- 5GENERAL INSTRUCTIONS
- 6TRANSPORT & LIFTING
- 6STORAGE
 - 6SHORT-TERM STORAGE
 - 7LONG-TERM STORAGE
- 7PUMP IDENTIFICATION
- 7MANUFACTURER
- 7CONSTRUCTION FEATURES
- 8NAMEPLATE INFORMATION
- 9WARRANTY
- 9RECOMMENDED PROCEDURE FOR BASE PLATE INSTALLATION & FINAL FIELD ALIGNMENT
- 11NOISE
- 11PUMP AND SHAFT ALIGNMENT
- 11INTAKE
- 12EXHAUST
- 13COOLING SYSTEM
- 17FUEL SYSTEM
- 17ELECTRICAL
- 18BATTERIES
- 18CONTROL PANEL
- 20ENGINE SPEED ADJUSTMENTS
- 21PREPARATIONS

21ADDING ENGINE OIL

22BATTERIES

22ENGINE START-UP/SHUT-DOWN

24WEEKLY TEST

24TROUBLESHOOTING

27MAINTENANCE

27PREVENTATIVE MAINTENANCE

27NEED FOR MAINTENANCE RECORDS

27NEED FOR CLEANLINESS

27DRIVESHAFT

27COUPLING GUARDS

27ROUTINE MAINTENANCE CHART

28ENGINE PUMP ROOM

28INTAKE SYSTEM

28CHECKING AND REPLACING THE AIR FILTER(S)

28CHECKING THE FUEL TANK AND FUEL LEVEL

28FUEL FILTER(S)

30CHECKING THE OIL LEVEL

31CHANGING THE DIESEL ENGINE OIL & OIL FILTER(S)

33REPLACING COOLANT

35BATTERIES

35DRIVE BELT

48DIESEL ENGINE BATTERIES, RACKS & CABLES

49DIESEL ENGINE BATTERY CABLE DIAGRAM

— AMERIFLO —

OVERVIEW

AMERIFLO has used the most current and advanced technology for research and design when engineering the diesel engine components of the product line. A concentrated focus on state-of-the-art quality control during the manufacturing process ensures safety and reliability as primary goals.

This manual is designed so that the end user becomes familiar with the characteristics and proper operation of the AMERIFLO diesel engine product line. This diesel engine product line has been designed for the sole purpose of driving stationary emergency fire pumps. Do not use these products for any other use.

This manual provides very important guidance for the installation, reliable operation and efficient maintenance when the need arises. The operating procedures must be strictly followed to ensure reliability of the product and to maximize the service life of the pump with a focus on avoiding injury and hazards.

Local laws & regulations are not taken into account in this manual as they can vary greatly from region to region. Operators must ensure total and strict compliance with local laws and regulations, including proper procedures required during the installation process.

Do not operate any equipment in excess of it's limits as specified in this operating manual, including transmission medium, flow, rated speed, density, pressure and temperature. The end user must ensure the operation of the pump & system is in accordance with this manual.

If you have any questions, please contact AMERIFLO with your serial number & nameplate information. AMERIFLO can assist you if damage has occurred to the equipment and/or if the need arises for spare parts.

SAFETY PRECAUTIONS

This installation, operation & maintenance manual contains general installation, operation and maintenance instructions that must be followed. This manual must be read and understood in it's entirety by the responsible personnel/operators prior to installation and commissioning and the manual must be kept readily available at the job site for easy access.

To minimize risk of injury or death, the "safety" provisions of this entire manual **MUST** be followed. AMERIFLO shall not be liable for physical injury, damage or delays caused by a failure to observe the instructions for installation, operation & maintenance contained in this manual.

Paying constant attention to safety is always extremely

important. This manual covers areas of danger that require additional attention. These areas of precaution are identified by using the following symbols:



DANGER - Immediate hazards which **WILL** result in severe personal injury or death.



WARNING - Hazards or unsafe practices which **COULD** result in severe personal injury or death.



CAUTION - Hazards or unsafe practices which **COULD** result in minor personal injury or property damage.



SHOCK HAZARD - ELECTRICAL Hazards are present which **COULD** result in severe personal injury or death.



ROTATING EQUIPMENT - Hazards are present which **COULD** result in severe personal injury or death.

Equipment maximum lifting speed of 15 FT/S [4.6 M/S] should not be exceeded.



In colder climates where liquid could freeze in the pump or engine, precautions must be made to make sure the fluid never freezes. Freezing fluid can damage equipment. Drain fluid from any piece of equipment in this environment.

Never start or run equipment without a proper prime. Significant damage to the equipment can occur.

Never operate any pump for an extended period of time with a closed discharge valve. The allowable amount of time a pump can operate in this condition depends on several variables at the job site. Contact AMERIFLO for proper engineering support.

Never operate any pump for an extended period of time below minimum flow. Temperature rise and extreme

Never operate any pump with a closed suction valve.

If excessive noise is heard from any rotating piece of equipment, shut the equipment down immediately.

Always lockout power before doing any maintenance on the pump or driver.

Never operate the pump & driver without a proper coupling guard in place.

This diesel engine has parts operating a very high speed and at high temperatures.

Proper pump room ventilation guidelines **MUST** be followed as diesel engine exhaust contains carbon monoxide and this can be deadly if not properly dealt with.



If any leaks of hazardous fluids are identified, shut the unit down immediately and address the issue.

PERSONNEL QUALIFICATION

All personnel involved in the installation, operation & maintenance must be fully qualified to manage, operate, maintain, inspect and install the diesel engine assembly. The responsibilities, competence and supervision of all personnel involved in installation, operation and maintenance must be clearly defined by the end user. Lack of knowledge must be addressed by means of training and instruction provided by sufficiently trained personnel. Upon request, the end user can contact AMERIFLO to train the operators and end user. In addition, it is the responsibility of the operator to ensure that the operating instructions contained in this manual are fully understood by all parties involved with the equipment.

NON-COMPLIANCE

Non-compliance with the safety instructions contained in this manual can result in an accident causing damage to equipment, the site and to personal injury or death. The end user is solely responsible for correctly installing all equipment and a safely run operation after installation.

INSPECTION & INSTALLATION

The operator will ensure that maintenance, inspection and installation is performed by authorized, qualified personnel who are thoroughly familiar with this manual

and the operation of this equipment. **WORK MUST BE PERFORMED ON A PUMP OR DIESEL ENGINE ONLY AFTER THE PIECE OF EQUIPMENT HAS BEEN COMPLETELY LOCKED OUT OF OPERATION.** When taking the diesel engine unit out of service always adhere to the strict procedures described in the manual. As soon as the work has been completed, re-install and re-activate any safety relevant devices and protective devices. Before returning the product to service, review all instructions before restarting any equipment.

UNAUTHORIZED MODIFICATION

Modifications or alterations to the diesel engine unit are only permitted with the manufacturer's prior written consent. Use only original spare parts or parts authorized by AMERIFLO. The use of other parts will invalidate any remaining warranty. Warranty relating to the pump and driver unit is only valid if the equipment is used in accordance with its intended use and only authentic AMERIFLO parts are used for maintenance and repair. Never operate the pump & driver outside of the limits stated in the pump data sheet and information contained in this manual.

GENERAL INSTRUCTIONS

The diesel engine must be examined upon arrival to ascertain any damage caused during shipment. If damaged, immediately notify the carrier and/or the sender. Confirm that the goods correspond exactly to the description on the shipping documents and report any differences as soon as possible to AMERIFLO. Always reference the diesel engine type and serial number stamped on the data plate.

The AMERIFLO diesel engine can be installed on the AMERIFLO end suction product line (ES), splitcase product line (SC) or the vertical turbine (VT) product lines. Refer to the specific pump product manual to use in conjunction with this diesel engine manual.

The diesel engine unit must be used only for applications for which AMERIFLO has specified:

- The construction materials
- The operating conditions (flow, pressure, temperature, etc.)
- The field of application

In case of doubt, contact AMERIFLO.

— AMERIFLO —

TRANSPORT & LIFTING

The diesel engine must be transported in the horizontal position.

Proper handling measures must be followed during transportation of equipment. Observe the following precautions.



CAUTION - Maximum lifting speed is 15 FT/S [4.6 M/S]

During all phases of transportation (truck, rail & ocean) all components must be handled and transported by using suitable slings and hoists. All handling should be carried out by specially trained personnel to avoid damage to the equipment and persons. The lifting rings attached to various components should be used exclusively to lift the components for which they have been supplied.



CAUTION - All equipment shall be bolted to a suitable pallet or strapped down appropriately during transport. All loose parts should be crated accordingly.



CAUTION - The lugs on the pump and diesel engine are only designed to lift that piece of equipment separately. When lifting the pump set attention needs to be placed on the tension direction. See below figure for proper lifting.

It is important to exercise extreme care in handling and installing all components. Certain items are precision machined for proper alignment and if dropped or mistreated in any way, misalignment and malfunction can result. The insulation on all wire must be protected. Parts which are too heavy to be lifted from the transporting vehicle should be skidded slowly and carefully to the ground to prevent damage. Never unload any item by dropping parts directly from the truck to the ground.

If job site conditions permit, you may be able to install directly from the truck that delivered the equipment. If not, move the components to the installation area and lay them out in a clean and protected space convenient to the work location.

If installation cannot begin within a few days after delivery, segregate and identify all components of the shipment so they will not be confused with other equipment arriving at the job site.

Read and follow the storage instructions carefully as care of the diesel engine during this period before installation can be as important as maintenance after operation has begun.

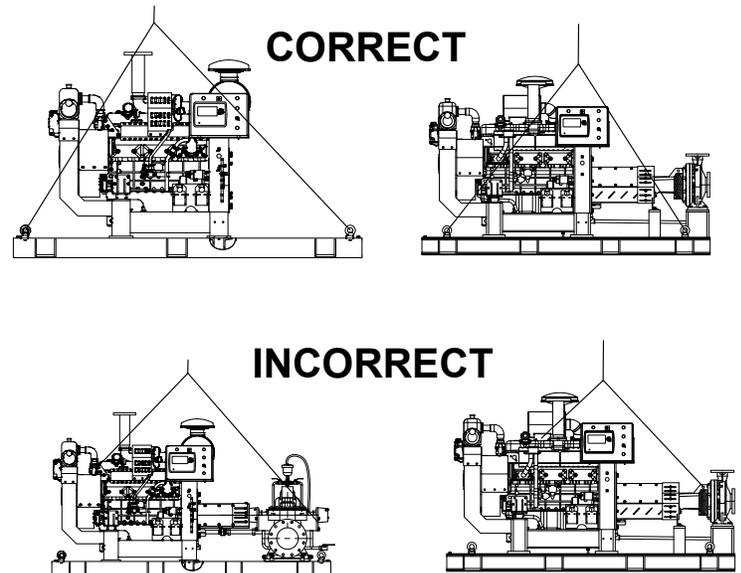

FIGURE 1 - PROPER LIFTING

Check all parts against the packing list to make sure nothing is missing. It is much better to find out now than during the installation. If damage occurred during transportation report it to the carrier immediately. Freight claims **MUST** be reported by the recipient. Report any item discrepancies immediately to AMERIFLO.

STORAGE

SHORT-TERM STORAGE

Normal shipment packaging is designed to protect the diesel engine during shipment and for dry, indoor storage for up to 12 months or less.

If the diesel engine is not to be installed or operated soon after delivery, store the unit in a clean, dry place, having slow changes in environmental conditions. Steps should be taken to protect the diesel engine against moisture, dirt and foreign particulate intrusion. During the short-term period, the diesel engine should be inspected periodically for moisture damage, theft, excessive dirt or any other condition that would adversely effect engine performance.

LONG-TERM STORAGE

Long-term storage is defined as more than 12 months. The procedure AMERIFLO follows for long-term storage of diesel engines is given below. These procedures are in addition to the short-term procedure above.

Solid wood skids are utilized. Holes are drilled in the skid to accommodate the anchor bolt holes in the base plate or the diesel engine skid. Tackwrap sheeting is then placed on top of the skid and the diesel engine assembly is placed on top of the Tackwrap. Metal bolts with washers and rubber bushings are inserted through the skid, the Tackwrap and the assembly from the bottom of the skid and are then secured with hex nuts. When the nuts are “snugged” down to the top of the base plate or casing and bearing housing feet, the rubber bushing is expanded, sealing the hole from the atmosphere. Desiccant bags are placed on the Tackwrap. The Tackwrap is drawn up around the assembly and hermetically (heat) sealed across the top. The assembly is completely sealed from the atmosphere and the desiccant will absorb any entrapped moisture. A solid wood box is then used to cover the assembly to provide protection from the elements and handling. This packaging will provide protection up to twelve months without damage to bearings, lip seals, etc. due to humidity, salt laden air, dust, etc. After unpacking, protection will be the responsibility of the user. If units are to be idle for extended periods, the addition of lubricants, inhibitor oils and greases should be used. When the unit is ready to be installed, replace all old lubricant with new lubricant.

Additional services are to be done to all AMERIFLO diesel engines:

- Drain all engine oil and discard all oil filters. Pre-fill and install new oil filter(s) with a MIL-L-21260E (15W-40) preservative oil.
- Refill the crankcase with a preservative oil meeting MIL-L-21260E (15W-40) standards as was previously done with the oil filter(s) above.
- Remove and reinstall all new fuel filters.
- If the engine does not have coolant present, fill the engine with coolants meeting ASTM-D4985 or GB24973 specifications for heavy duty diesel engines. Ensure that the mixture is a 50% - 50% mixture of coolant and water. Premix the solution outside of the engine before filling the engine.
- Remove all intake and exhaust coverings that were in place during shipment.
- Prepare a fuel container with a mixture of diesel fuel

conditioner with ASTM D975, 2-D diesel fuel (0% biodiesel) or approved equal.

- Remove the coupling between the diesel engine and pump assembly (if previously installed).
- With fully charged batteries, start and run the uncoupled diesel engine for 1 - 2 minutes monitoring diesel engine temperatures and making sure these temperatures do not exceed maximum values.
- Shut the engine down. Drain all diesel engine oil and coolant from the unit.
- Re-install all intake and exhaust coverings that were in place during shipment.
- Place proper labeling on the engine notifying everyone that the engine has no oil or coolant present.

This long-term procedure is to be performed every 6 months the diesel engine is to remain in long-term storage.

When the diesel engine is ready to be placed into service, following the steps below:

- Install proper oil filter(s), fuel filter(s) and air filter(s).
- Fill the diesel engine crankcase with normal, recommended oil to the proper level as indicated on the dipstick.
- Remove all intake and exhaust coverings that were in place during long-term storage.
- Fill the diesel engine cooling system with normal, recommended coolant to the proper level as indicated on the reservoir.
- Follow all steps in this Installation, Operation & Maintenance manual for proper diesel engine startup.

PUMP IDENTIFICATION**MANUFACTURER**

AMERIFLO
125 Morrison Road, Rossville TN 38066
United States of America

www.ameriflo-usa.com

CONSTRUCTION FEATURES

The diesel engine product line is a horizontal, multi-cylinder, heavy duty diesel engine assembly. This engine is of the compression ignition type and uses the coolant

NAMEPLATE INFORMATION

(water and glycol mixture) to cool all cylinders in a water jacket. The fuel pump is of the mechanical governor type, with direct injection and the engine has a pre-heater installed. This diesel engine is to be used only for emergency fire protection. The diesel engine is used only for fire protection applications. The diesel engine is started by the diesel engine controller, the automatic start controller used for start, automatic or manual stop after a proper signal is detected. Pressure and temperature sensing is provide to guarantee proper engine performance. The following information will provide proper operating instructions to avoid accidents during installation, usage and maintenance. The engine operator must read and follow the manual and pay special attention to all warnings.

The supplied diesel engine is designed only for driving stationary emergency fire pumps. This diesel engine cannot be used for other purposes.

- The supplied electrical power can not to be greater than the rating on the diesel engine name plate.
- All of the diesel engines are supplied and produced by AMERIFLO with stringent quality control standards in place at each step of production up to and including run testing of each and every diesel engine prior to shipment.
- Do not store any AMERIFLO diesel engine for more than one year.

If the end user encounters any issues with proper diesel engine start-up, contact AMERIFLO for service help and instructions.

DATE OF MANUFACTURER

The date of manufacture is indicated on the Sales Order paperwork.

INSTALLATION, OPERATION & MAINTENANCE MANUAL IDENTIFICATION

PREPARED: APRIL 1, 2021
REVISION:

EDITION: 01
DATE:

AMERIFLO
125 MORRISON ROAD
ROSSVILLE, TN 38066
UNITED STATES OF AMERICA

UL LISTED **FM APPROVED**

INTERNAL COMBUSTION ENGINES FOR DRIVING STATIONARY FIRE PUMPS

MODEL: _____

SERIAL NUMBER: _____

RATED POWER OUTPUT: _____ HP (KW)

RATED SPEED: _____ RPM

MINIMUM SPEED/POWER: _____ RPM _____ HP (KW)

MAXIMUM SPEED/POWER: _____ RPM _____ HP (KW)

MANUFACTURE DATE: _____

FUEL GRADE: _____
ASTM D975 2-D, GB 252 OR EQUIVALENT

HORSEPOWER RATINGS WITHIN THE SPECIFIED SPEED RANGE ARE TO BE DETERMINED BY THE USE OF LINEAR INTERPOLATION BETWEEN THE HORSEPOWER DEVELOPED AT MINIMUM AND MAXIMUM SPEEDS

FIGURE 2 - DIESEL ENGINE NAMEPLATE

MODEL:

Model of the diesel engine

SERIAL NUMBER:

Serial number of the pump issued by Production Control

RATED POWER OUTPUT:

Rated power output of the diesel engine in Horsepower & Kilowatts

RATED SPEED:

Rated speed of the diesel engine in Revolutions Per Minute

MINIMUM SPEED/POWER:

Minimum speed in Revolutions Per Minute and power generated in Horsepower & Kilowatts

MAXIMUM SPEED/POWER:

Maximum speed in Revolutions Per Minute and power generated in Horsepower & Kilowatts

MANUFACTURE DATE:

Diesel engine manufacture date

FUEL GRADE:

Acceptable fuel grade that the diesel engine is certified to operate on

AMERIFLO offers new equipment manufactured by seller or service supplied by seller to be warranted to be free from defects in material and craftsmanship under normal use and service for a period of one year from date of shipment. Further details of the AMERIFLO warranty can be obtained from your AMERIFLO customer service representative.

Do not remove the diesel engine warranty seal PRIOR to contacting AMERIFLO for warranty consideration. Removing the diesel engine warranty seal without PRIOR AMERIFLO permission can invalidate a potential warranty claim.

INSTALLATION

RECOMMENDED PROCEDURE FOR BASE PLATE INSTALLATION & FINAL FIELD ALIGNMENT

NEW GROUTED BASE PLATES

Refer to the appropriate AMERIFLO pump Installation, Operation & Maintenance manual for proper field installation onto the foundation. Following these instructions is essential to having a complete unit operate successfully.

1. The diesel engine foundation should be located as close to the source of the fluid to be pumped as practical. There should be adequate space for workers to install, operate and maintain the diesel engine including room to remove the unit for maintenance at a future date. The foundation should be sufficient enough to absorb any vibration and should provide a rigid support for the pump and diesel engine. The foundation's mass should be three (3) times that of the complete installed assembly (at a minimum). Recommended alignment of the baseplate is accomplished by adjusting the mounting hardware. After alignment, the baseplate is supported by metallic shims or wedges. These metallic shims or wedges are used to support the baseplate during the process of concrete pouring (grouting) of the anchor bolts. In order to avoid torsional twisting of the baseplate during the installation process, metallic shims or wedges should be placed as close to the anchor bolt locations as possible. The metallic shims or wedges are fixed permanently in location by pouring grout at a later step.
2. Special attention must be paid to the baseplate during the foundation installation making sure stress is not induced on the baseplate. The diesel engine end of the baseplate shall not be higher than the pump at any condition and the deviation shall not exceed ± 0.004 IN/FT [0.1 MM/M] between the baseplate and horizontal level. Recommended mass of the concrete foundation should be three (3) times that of the complete installed assembly (at a minimum). Note that foundation bolts are imbedded in the concrete inside a sleeve to allow some movement of the bolt making installation easier.
3. Level the diesel engine/pump baseplate assembly. If the baseplate has machined coplanar mounting surfaces, these machined surfaces are to be referenced when leveling the baseplate. This may require that the pump and diesel engine be removed from the baseplate in order to reference the machined faces. If the baseplate is without machined coplanar mounting surfaces, the pump and diesel engine are to be left on the baseplate. The proper surfaces to reference when leveling the pump baseplate assembly are the pump suction and discharge flanges. **DO NOT** stress the baseplate. **DO NOT** bolt the suction or discharge flanges of the pump to the system piping until the baseplate foundation is completely installed. Use shims and wedges to level the baseplate to the foundation. See FIGURE 3. Check for level in both the longitudinal and lateral directions. Shims or wedges should be placed at all baseplate anchor bolt locations and in the middle of the baseplate if the base is more than five feet [1.5 meters] long. Do not rely on the bottom of the baseplate to be flat. Standard base plate bottoms are not machined and it is not likely that the field foundation surface is flat either.
4. After leveling the baseplate, tighten the anchor bolts in a diagonal pattern evenly. If shims or wedges were used, make sure that the baseplate was shimmed near each anchor bolt before tightening. Failure to do this may result in a torsional twisting of the baseplate, which could make it impossible to obtain a final and correct field alignment. Check the level of the baseplate to make sure that tightening of the anchor bolts did not disturb the level of the baseplate in any manner. If the anchor bolts did change the level, adjust the jackscrews or shims as needed to level the base plate again. Continue adjusting the jackscrews or shims and tightening the anchor bolts until the base plate is level.

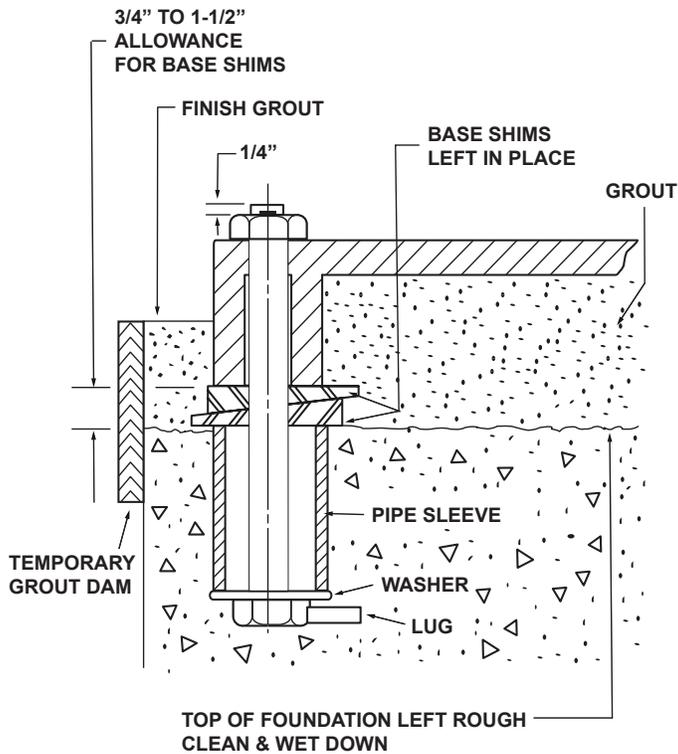

FIGURE 3 - BASEPLATE FOUNDATION

5. Check initial alignment of the pump and diesel engine. If the pump and diesel engine were removed from the baseplate proceed with step 6 first, then the pump and motor should be reinstalled onto the baseplate using AMERIFLO Factory Preliminary Alignment Procedure. Once completed, continue with the following. Pump assemblies are given a preliminary factory alignment PRIOR to shipment. This preliminary factory alignment is done in such a way that, if the installer duplicates the factory conditions, there will be sufficient clearance between the pump/motor hold down bolts and the pump/diesel engine foot holes to move the pump/motor into final alignment. If the pump and diesel engine were properly reinstalled to the baseplate or if they were not removed from the baseplate and there has been no damage during transit, and also if the above steps were done properly, the pump and driver should be within 0.015 IN [0.38 MM] FIM (Full Indicator Movement) parallel and 0.0025 IN/IN [0.0025 MM/MM] FIM angular alignment. If this is not the case first check to see if the driver mounting fasteners are centered in the driver feet holes. If not, re-center the fasteners and perform a preliminary alignment to the above tolerances by shimming under the motor for vertical alignment and by moving the pump for horizontal alignment.

6. GROUT THE BASEPLATE. A non-shrinking grout should be used. Grout compensates for uneven foundation, distributes weight of the unit and prevents the entire installation from shifting. Use only an approved, non-shrinking grout after setting and leveling the unit.

- a. Build a strong form around the foundation to contain the grout.
- b. Soak the top of the concrete foundation thoroughly and remove all surface water.
- c. A raised diesel engine pedestal should also be completely filled with grout during this process.
- d. After the grout has thoroughly hardened, check the foundation bolts and tighten if necessary.
- e. Approximately 14 days after the grout has been poured or when the grout has thoroughly cured, apply an oil base paint to the exposed edges of the grout to prevent air and moisture from coming in contact with the grout.

Make sure that the grout completely fills the area under the baseplate or in the case of an I-beam base, all compartments are completely filled to the top. After the grout has cured, check for voids and repair them.



CAUTION - Once the baseplate is grouted, the baseplate cannot be adjusted so it is extremely important that all alignment procedures be completed PRIOR to grouting.

7. Run the system piping to the suction and discharge flanges of the pump. There should be no piping loads transmitted to the pump after connection is made. Recheck the alignment to verify that there are no significant loads being transferred to the pump. Remember, pipe strain is invisible and alignment checks must be made after system connection to make sure none exist.

EXISTING GROUTED BASE PLATES

When a pump and diesel engine is being installed on an existing grouted baseplate, the procedure is somewhat different from the previous section “New Grouted Base Plates.”

1. Mount the pump on the existing baseplate.
2. Level the pump by putting a level on the discharge flange. If not level, add or delete shims between the pump foot and the baseplate.
3. Check initial field alignment. (Step 5 above)
4. Run the piping to the suction and discharge flanges of

the pump. (Step 7 above)

5. Perform final field alignment. (See below)
6. Recheck field alignment after the pump is hot. (See below)

All piping (including exhaust piping) must be independently supported, accurately aligned and preferably connected to the pump by a short length of flexible piping. The pump should not have to support the weight of the pipe or compensate for misalignment. It should be possible to install suction and discharge bolts through mating flanges without pulling or prying either of the flanges.

NOISE

This diesel engine unit can product noise in excess of 108 dBA without a sound attenuation enclosure. Hearing protection precautions must be in place while in proximity to the diesel engine when in operation.



DANGER - Continuous exposure to sound levels in excess of 85 dBA can cause permanent hearing loss. Hearing protection must be worn when near the operating diesel engine.

PUMP AND SHAFT ALIGNMENT

DIESEL ENGINE

During the factory alignment of diesel engine driven units, the concentricity between the pump and the diesel engine has been adjusted, however, movement during transportation is possible. Make sure that the driveshaft and all mounting hardware are checked PRIOR to pump start up. Before removing the driveshaft guard, make sure the negative battery cable is disconnected from both batteries.

After the diesel engine is connected to the pump through the driveshaft and universal couplings, make sure that the two coupling end faces of the universal coupling are kept parallel.

The diesel bearing center and the pump bearing center must be aligned with the centerline of the driveshaft, allowing for a maximum deviation of ± 0.03 in [± 0.76 mm]. See FIGURE 4.

Make sure that coupling and driveshaft universal joints are properly lubricated with NLGI #2 grease at the zerk fittings.

All capscrews used in the driveshaft area should have a threadlocker applied (similar to Loctite 243 - Blue) and

be torqued to the values shown in TABLE 12. The pump companion flange set screws should be torqued to the values shown in RABLE 13.

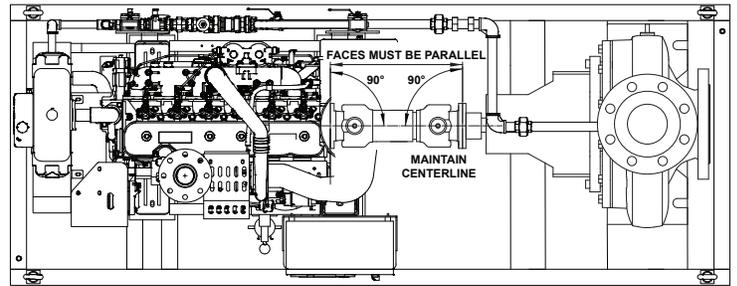

FIGURE 4 - DIESEL ENGINE DRIVESHAFT

Confirm that the distance from the driveshaft to the universal joint is only half of the total travel available. There should still be space available for movement when ready to operate.

The diesel engine bearing centerline and the pump bearing centerline angle must be kept to 2° (with a $\pm 1^\circ$ deviation). See FIGURE 5.

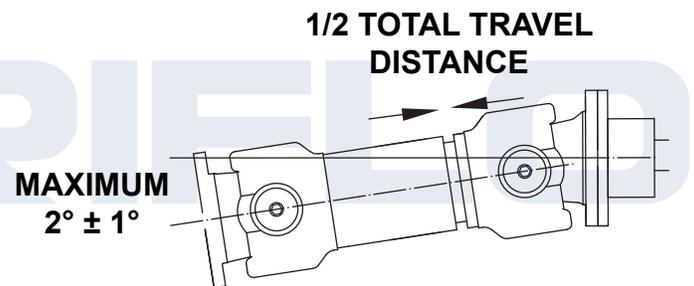

FIGURE 5 - DIESEL ENGINE OFFSET ANGLE & SPACING

INTAKE

All AMERIFLO diesel engines are tested in accordance to SAE J1349 standards. Certain environmental conditions will derate engine performance and these conditions MUST be identified before any diesel engine is put into operation.

Refer to the specific Engine Data Package (EDP) from AMERIFLO for a detailed description of all systems contained in the diesel engine.

For every 1,000 FT [305 M] of elevation over 300 FT [91 M], the engine must be derated by 3%.

For every 10°F [5.6°C] of temperature above 77°F [25°C], the engine must be derated by 1%.

Keep in mind that certain installations may have an elevation and temperature correction. In this case, derate for elevation first and then derate for temperature.

Air for diesel engine combustion must be clean and as cool as possible for maximum performance. In most installations, this air can be drawn from the area immediately surrounding the diesel engine via the diesel engine mounted air filter. However, in certain situations due to dust, dirt or high temperatures immediately surrounding the diesel engine, the air around the pump set is unsuitable. In these scenarios an inlet duct should be fitted to the diesel engine and this duct should be routed to an alternate location (outside the building, to another room, etc.). In this alternate scenario, DO NOT remove the air filter and mount it at a remote location as this can increase the possibility of contaminants leaking through the ductwork and into the diesel engine inlet. To ensure that this type of installation will not have a detrimental effect on the operation of the diesel engine, the design of the inlet duct MUST be approved by AMERIFLO prior to installation.

PRIOR to start-up, make sure all protective coatings are removed from the air intake area.

The purpose of the diesel engine exhaust system is to exhaust the noxious fumes from the engine to the outside and to reduce exhaust noise. A suitable exhaust silencer must be incorporated into the exhaust piping to reduce the noise level from the engine. It can be fitted either inside or outside of the building.

Excessive back pressure to the diesel engine can considerably effect diesel engine performance and diesel engine life. The exhaust piping must be of the proper diameter, have a minimum number of bends and be as short as possible so as to not cause a detrimental effect on diesel engine performance.



Diesel engine exhaust contains carbon monoxide, an odorless gas, that can lead to death. All exhaust gases must be routed to an outside location.

Figure 6 show a typical installation for ventilation and exhaust piping.



WARNING - The back pressure to the engine exhaust considerably influences the power of the engine and it's thermal loading. Excessive back pressure measured at the engine exhaust outlet connection (point a) will decrease power,

EXHAUST

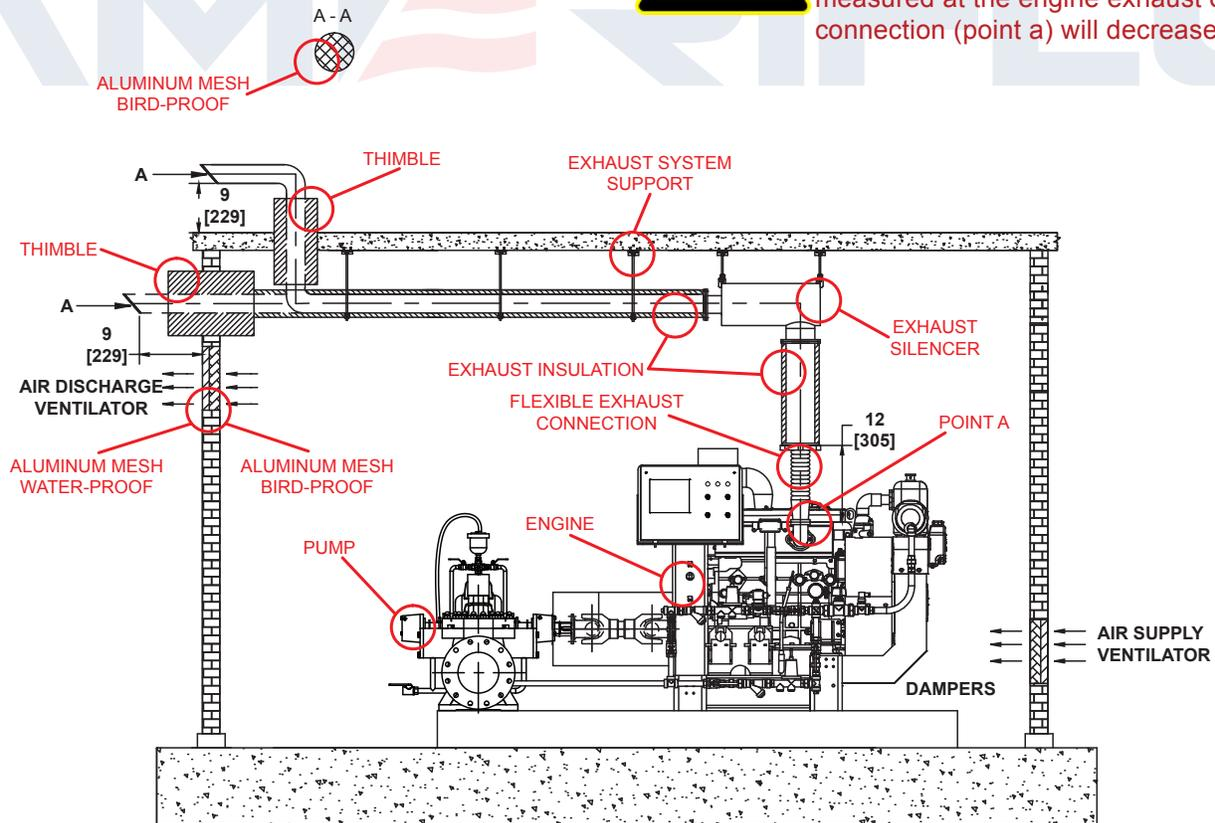

FIGURE 6 - DIESEL ENGINE INTAKE, EXHAUST & VENTILATION REQUIREMENTS

DATE **APRIL 2021**

increase the temperature of the exhaust gas, produce smoke, increase fuel consumption, sulfurizes the internal cooling water (with subsequent damage to the lubricants) and produces serious consequences for other engine elements (i.e. turbocharger, etc.).

When designing the exhaust system, the following MUST be considered:

- When the diesel engine is installed inside of a building, a leakproof exhaust system MUST be installed to protect personnel from exhaust fumes.
- The exhaust system MUST be designed with the shortest run possible, minimal number of bends (with a curve radius of 1.5 times the pipe diameter) and supported properly.
- A flexible connection between the exhaust manifold on the diesel engine and the exhaust piping system must be used to prevent transmission of engine vibration to the piping (and the building) and to allow for thermal expansion and any slight misalignment of the exhaust piping.
- Ensure that the diesel engine silencer and all piping are well supported to limit strain on the connectors which could result in cracks or leaks in the exhaust piping.
- All exhaust piping must have thermal protection applied to reduce injury to personnel and be routed away from all flammable substances.
- Exhaust system components located indoors must be insulated to reduce heat radiation and noise levels.
- The silencer must be installed in the horizontal direction.
- Any long horizontal or vertical piping should include drain traps at the lowest points to prevent water from reaching the engine or silencer.
- Where the exhaust piping goes through a wall, there must be a gap (Minimum 0.250 IN [5 MM]) between the piping and surrounding material due to thermal expansion.
- Install expansion joints in the exhaust piping to compensate for lengthwise thermal expansion and/or contraction.
- The end of the exhaust pipe, if horizontal, should be cut at 60° angle. A rain hood or cap is needed if there is a vertical termination to prevent moisture from entering the exhaust system.

- The exhaust piping must not be connected to other exhaust systems located at the installation.
- The exhaust pipe installation should be as short as possible with a minimum number of elbows. Avoid 90° bends in the exhaust piping.
- If welding exhaust piping, make sure all weld slag is removed from the exhaust piping prior to diesel engine operation.

VENTILATION

The diesel engine and pump room must be provided with adequate ventilation to satisfy the requirements of the combustion system, heat exchanger cooling system and dissipation of radiated heat from the diesel engine itself. See FIGURE 6.

COOLING SYSTEM

HEAT EXCHANGER

All AMERIFLO diesel engines are provided with a heat exchanger to maintain the diesel engine coolant temperature within the specified range. The thermostat range is listed in TABLE 1.

THERMOSTAT RANGE	
START OPEN	160°F [71°C]
FULL OPEN	185°F [85°C]

TABLE 1 - THERMOSTAT RANGE

Water can create a corrosive environment within the diesel engine and other material in the water can cause scale to form on interior surfaces. These other materials can cause damage to the diesel engine and attention to making sure they do not exist in the fluid must be taken. See TABLE 2 for maximum percentages of certain dissolved solids that can be present.

MATERIAL (MAXIMUM)	PARTS PER MILLION	GRAINS PER MILLION
CHLORIDES	40	2.5
SULFATES	100	5.8
TOTAL DISSOLVED SOLIDS	340	20
TOTAL HARDNESS	170	10

TABLE 2 - MAXIMUM DISSOLVED SOLIDS PRESENT

COOLANT

The diesel engine has a closed inner loop that is used to cool the diesel engine. This inner loop must be filled with a mixture of water and ethylene glycol or propylene glycol to prevent freezing, protection from cavitation damage, corrosion, erosion and the formation of scale internal to the diesel engine.



WARNING - A 50% water and 50% ethylene solution is required for all diesel engine operations. Pre-mix the mixture before installation to prevent pure ethylene from coming into contact with certain diesel engine components. This will prevent possible chemical attack of certain diesel engine components.

Do not use a mixture of ethylene glycol and propylene glycol. Use one or the other only at a single time. Do not use coolants with nitrites present as this can cause damage to the diesel engine. AMERIFLO recommends a coolant that meets ASTM D-4985 or GB24973 requirements. Coolant capacity is listed in TABLE 3.

Do not use a concentration of glycol over 70% as it offers an inferior heat transfer ability, adverse freezing protection and a possible silicate dropout. Concentrations below 30% offer little freezing protection, boiling of the coolant in the inner loop and little corrosion protection to the diesel engine.



WARNING - Do not use automotive type coolants (i.e. to ASTM d-3306) in AMERIFLO diesel engines. These coolants do not have the proper additives to protect heavy-duty diesel engines and may damage the diesel engine and/or cooling loop.

DIESEL ENGINE	COOLANT CAPACITY QUARTS [LITERS]
AF12-128C	71.9 [68]

TABLE 3 - COOLANT VOLUME

Coolant inhibitors are also recommended by AMERIFLO to resist corrosion, cavitation protection, maintain proper pH levels and prevents the formation of scale. Inhibitors become depleted over time so the addition of coolant inhibitors is needed to maintain proper strength levels. TABLE 4 shows proper coolant inhibitor strength levels.

INHIBITOR	MINIMUM PARTS PER MILLION	MAXIMUM PARTS PER MILLION
BORON (B)	1000	1500
NITRITE (NO ₂)	800	2400
NITRATES (NO ₃)	1000	2000
SILICON (SI)	50	250
PHOSPHOROUS (P)	300	500
PH LEVEL	8.5	10.5

TABLE 4 - COOLANT INHIBITOR LEVELS

Contact AMERIFLO for coolant inhibitor kits to properly measure coolant inhibitor levels.

The diesel engine thermostat will remain closed after the engine starts up. The internal coolant loop will not be active until the thermostat opens up. At that time, the water pump will circulate coolant through the heat exchanger and back to the diesel engine. If the coolant temperature drops the thermostat will close and the loop will remain non-active until a future temperature rise. See FIGURE 7.

All AMERIFLO diesel engines ship with coolant from the factory. When filling the coolant system, air pockets may form inside the engine.

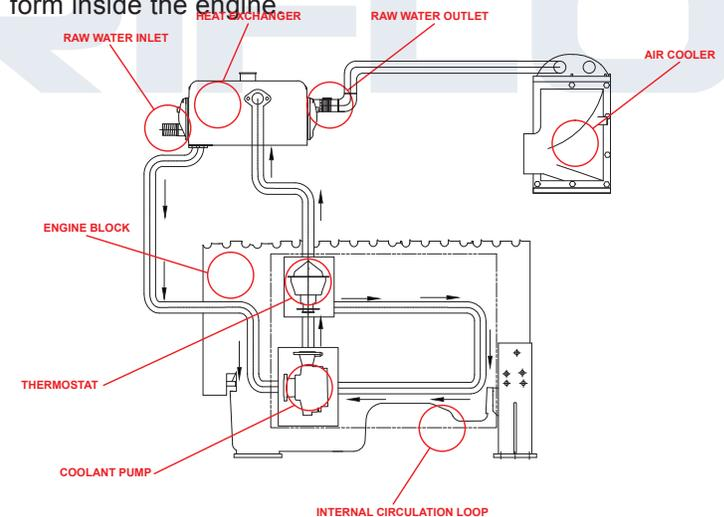

FIGURE 7 - INTERNAL COOLING LOOP WITH AIR COOLER



CAUTION - Do not overfill the coolant system. This system is pressurized and will need room for expansion and contraction without overflowing. Always use the level lines on the expansion vessel as a guide.

The coolant level can be seen at any time in the plastic expansion vessel which is located on front of the heat exchanger. See FIGURE 8.

Install the coolant cap and run the engine for approximately 5 minutes to purge any trapped air that may be present inside of the engine. Before adding additional coolant, make sure that the engine temperature is at 120°F (49°C) or lower before removing the coolant cap. Remove the cap and add coolant if the coolant level is not between the acceptable level lines as indicated on the expansion vessel.

Allow the diesel engine to run for 10 to 15 minutes so that the entire unit can warm to a stable temperature. Repeat the filling process until the coolant stabilized and is at the proper level.

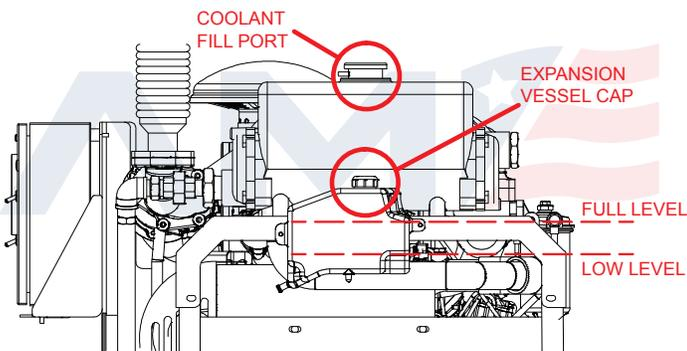

FIGURE 8 - PROPER COOLANT LEVEL



DANGER - Never remove the coolant cap while the coolant is at normal operating temperatures. Doing so could result in severe burns due to the presence of very hot, pressurized fluid.

RAW WATER

All AMERIFLO diesel engines use an external cooling loop that is fed raw water from the fire pump. For end suction and splitcase pump applications, this external loop will be connected at the factory. For vertical turbine applications, due to the fact that the discharge head may or may not be mounted on a common base, external plumbing by others connected this cooling line may be required. The cooling loop MUST receive raw water from the fire pump to operate properly. See FIGURE 9.

The cooling loop consists of two possible flow conditions, Normal and Bypass. In normal operations, valves #1 and #2 are in the open position and valves #3 and #4 are in the closed position. The normal operations cooling loop has a solenoid valve (normally closed) that will open and close based on a signal from the controller or diesel engine. Anytime the diesel engine is turned on, this solenoid valve will open. The Bypass cooling loop is a manually actuated loop used in the case of high diesel engine operating temperatures or solenoid valve failure.

Each pressure loop has a pressure regulator present which protects the downstream heat exchanger from over pressurization. Certain AMERIFLO pumps are capable of generating pressures above the maximum pressure rating of components present on the diesel engine. The pressure regulators make sure that the downstream heat exchanger only has 14.5 - 43.5 PSI [1 - 3 BAR] pressure present. A pressure gauge is present in the loop, downstream from either the Normal or Bypass loop, for an indication of cooling loop pressure.

The pressure regulators are initially adjusted at the factory prior to shipment. Fine tuning in the field may be required and should be addressed during start-up. To accomplish this, operate the pump at 150% capacity and use the adjusting screw on top of the pressure regulator to increase or decrease flow through the cooling loop. To increase flow, adjust the screw clockwise and to reduce flow adjust the screw counter-clockwise. All AMERIFLO diesel engine cooling loops have a temperature probe and flowmeter to monitor raw water properties.

The Normal and Bypass cooling loops each have a wye strainer present and must be part of the standard maintenance schedule.



CAUTION - Most diesel engine failures are due to clogged cooling loop strainers. It is imperative that these strainers be checked as part of a good maintenance plan.

Both the Normal and Bypass loops can be opened at the same time without an adverse effect on the diesel engine.

RAW WATER OUTLET

Piping must be installed on the output side of the heat exchanger so that this flow can be visually observed. Under no circumstances can the piping be smaller than the outlet on the heat exchanger. This discharge line shall be as short as possible, discharged to a visible waste cone location and have no valves present. This piping can be piped to an external reservoir (per NFPA 20) with the following conditions:

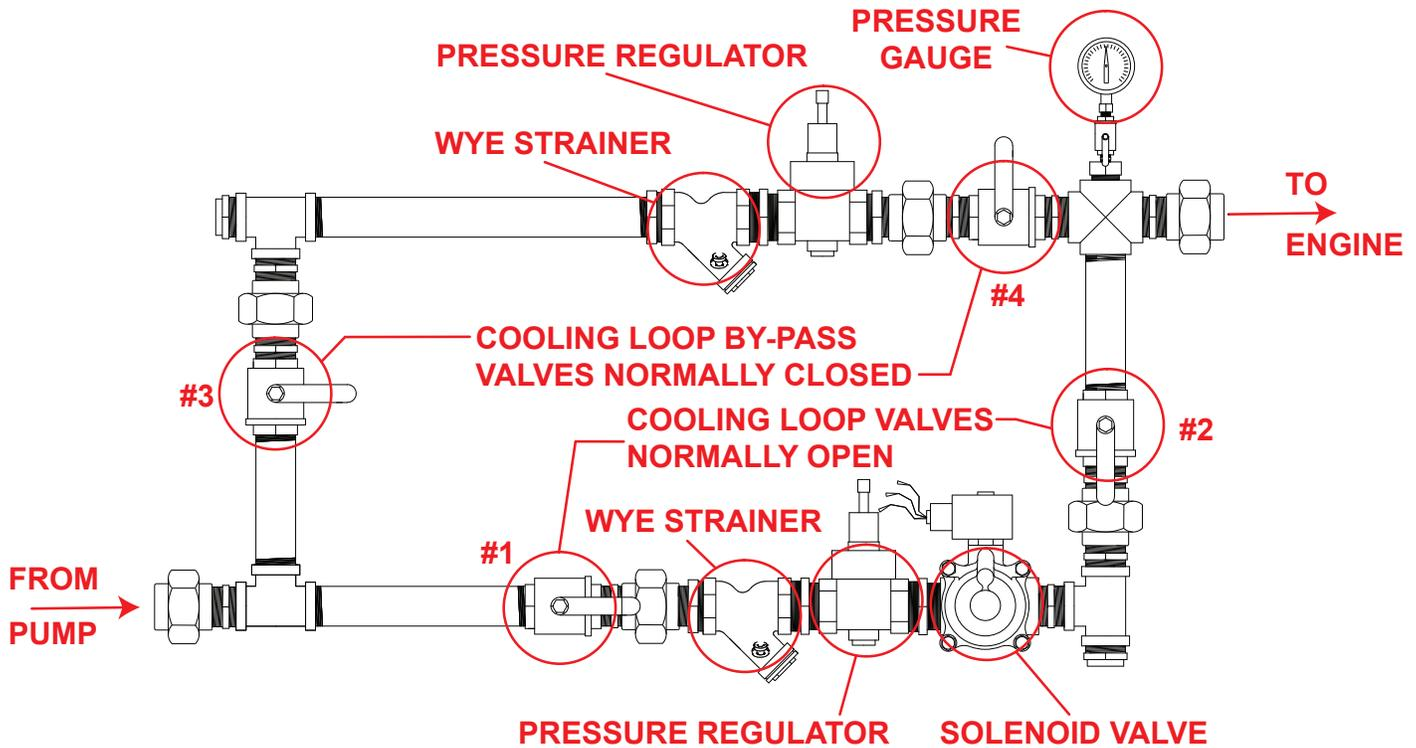

FIGURE 9 - DIESEL ENGINE EXTERNAL COOLING LOOP PRE-HEATING SYSTEM

- A visual flow indication must be present as well as a means for temperature measurement. If the piping is longer than 15 FT [4.6 M] or the outlet is more than 4 FT [1.2 M] higher than the heat exchanger, the piping must be increased to the next larger size.
- Verify that the heat exchanger pressure does not exceed 43.5 PSI [3 BAR] and that the discharge heat exchanger fluid is not more than 40°F [4.5°C] higher than the raw water temperature from the fire pump when operating at the 150% flow point.

Local jurisdiction laws may only allow for certain heat exchanger discharge options. Consult with the authority in your region for guidelines.

Anytime a cooling system issue is encountered, high temperature alarm, collapsed hose, etc., it is recommended by AMERIFLO that the issue must be investigated and the sources identified. In certain cases, drain the coolant, replace the diesel engine thermostat(s), remove and inspect the diesel engine water pump and inspect all parts for damage. Once the issue has been identified and corrected, refill the coolant per the instructions above.

All AMERIFLO diesel engines have a pre-heater installed to maintain a consistent engine temperature. This pre-heater makes sure the engine block is not subject to very cold temperatures causing diesel engine starting issues. The pre-heater is automatically controlled and will turn on at 113°F [40°C] and turn off at 140°F [60°C]. This ensures that the engine block temperature will always be at a temperature that will allow the diesel engine to easy and quickly start. Connect the pre-heater to AC power per local electrical codes and requirements. Wiring should never be routed through the AMERIFLO diesel engine controller. SEE FIGURE 10.



FIGURE 10 - PRE-HEATER

FUEL PUMP

All AMERIFLO diesel engines are designed to use 2D diesel engine fuel. All diesel fuel used must be maintained in a quality state per NFPA 25 - 2014 guidelines. Fuel with a sulfur content of greater than 1% cannot be used. Acceptable fuel grade must be compatible with ASTM D975 DF#2 or GB252.

DIESEL ENGINE	FUEL PUMP TYPE
AF12-128C	INLINE, MECHANICAL TYPE

TABLE 5 - FUEL PUMP TYPE

An electric solenoid valve on the engine is used to control fuel delivery. In an emergency, the solenoid valve can be bypassed if it is not operating correctly. The diesel fuel pump is a TQA type and fuel pressure is adjusted by the discharge valve located on the fuel pump. The diesel fuel pump is lubricated with oil pressure from the diesel engine oil pump. Refer to the MAINTENANCE section of this manual to perform a variety of services on the fuel system.

DIESEL FUEL INJECTOR

The purpose of the diesel fuel injectors is to spray, atomized fuel into the combustion chamber so that the air/fuel mixture can be burned efficiently.

FUEL SUPPLY & RETURN LINES

The supply and return diesel fuel lines are of a flame resistant type that are compatible with diesel fuel. Connect both the supply and return lines to the diesel engine. For piping sizes, refer to the Engine Data Package (EDP) at the end of this manual.

FUEL TANK

Depending on your location, AMERIFLO can supply a single wall or double wall fuel tank. Always keep the fuel tank filled to reduce condensation within the fuel tank. Open the drain at the bottom of the tank at least once per week to drain off any accumulated moisture. After each weekly test make sure the fuel tank is refilled.



CAUTION - Per NFPA 25 standards, the fuel tank level must never be less than 67% of its capacity.

FUEL FILTER

This AMERIFLO diesel engine uses a fuel filter consisting of a paper element.

DIESEL ENGINE	FUEL PUMP TYPE
AF12-128C	DUAL, PAPER ELEMENT

TABLE 6 - FUEL FILTER TYPE

LUBRICATION SYSTEM

All AMERIFLO diesel engines have a lubrication system that reduces wear and corrosion of internal diesel engine components. Maintaining proper diesel engine oil levels is a must as catastrophic engine failure can occur otherwise. Multi-grade oil is recommended due to its wide ambient temperature range. See TABLE 7 for recommended oils based on ambient temperature conditions.

OIL GRADE	AMBIENT TEMPERATURE	
	MINIMUM	MAXIMUM
5W-40	-40°F [-40°C]	122°F [50°C]
10W-30	-22°F [-30°C]	86°F [30°C]
10W-40	-22°F [-30°C]	104°F [40°C]
15W-40	-4°F [-20°C]	104°F [40°C]
20W-50	14°F [-10°C]	122°F [50°C]

TABLE 7 - OIL VISCOSITIES BASED ON AMBIENT TEMPERATURE

Diesel engine oil and filters should be replaced every 30 hours of operation. AMERIFLO recommends 15W-40 oil viscosity for normal applications meeting the requirements of CF-4, CG-4, CH-4 or CI-4. The diesel engine is pre-filled with oil at the factory.

Remove the dipstick and clean with a lint free, clean cloth. Check proper oil level PRIOR to starting the diesel engine. See FIGURE 11.

This diesel engine uses a single oil filter consisting of a paper element. Refer to the MAINTENANCE section of this manual to perform a variety of services on the lubrication system.

ELECTRICAL

All AMERIFLO diesel engines operate on a 24 volt DC negative ground system. See illustration at the end of this manual for battery wiring information.

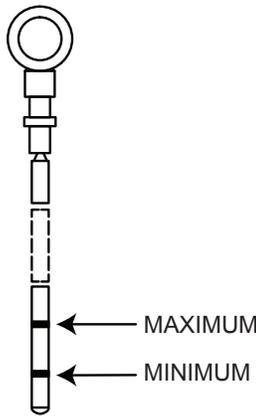

FIGURE 11 - PROPER OIL LEVEL

recharging of two independent DC sources (batteries) by the alternator while the diesel engine is operating. The battery voltage can be monitored from the AMERITOUCH diesel engine controller or by the third party fire pump controller.

The AMERITOUCH diesel engine controller can display the following information:

- Charging voltage from the alternator (digital voltmeter in the LCD)
- Voltage of all batteries (digital voltmeter in the LCD)
- Total diesel engine run time
- Water temperature of the diesel engine while running (digital thermometer, LCD)
- Water temperature of the diesel engine during standby (digital thermometer, LCD)
- Rotational speed of the diesel engine (digital tachometer, LCD)
- Oil pressure of the diesel engine (digital pressure gauge, LCD)
- Number of time diesel engine started, digital counter, LCD)

Accuracy of the above engine data is $\pm 5\%$ and the digital tachometer is ± 25 Revolutions Per Minute (RPM).

REFERENCES

The AMERITOUCH panel meets the following standards and regulations:

- NFPA 20
- CCC
- NF C15 100
- NF EN60 439.1
- NF EN60 259
- NF EN60 947
- NF EN60-269
- UL 50/508
- UL 1247/6.1
- FM 1333/3.3/3.4

CONSTRUCTION INFORMATION

The AMERITOUCH cabinet is made of a painted sheet metal, with an enclosure rating of IP44 or NEMA 3. This standard enclosure is rated for fire pump applications and for humid environments.

Specific wiring diagrams are included with the panel for

BATTERIES

The battery bank for AMERIFLO diesel engines consists of 4, 12 volt batteries. The batteries are shipped without electrolyte. Filling of the batteries in the field prior to charging is required. Make sure the batteries are charged for a minimum of 24 hours before starting.



DANGER - If sulfuric acid makes direct contact with the eyes, it can cause permanent blindness. If ingested, this chemical may cause internal burns, irreversible organ damage, and possibly death. Exposure to sulfuric acid aerosols at high concentrations leads to severe eye and respiratory tract irritation and tissue damage.

Batteries must be charged by two methods, from the diesel engine alternator and by a reliable AC power source while the diesel engine is not in operation. If the AC power is unreliable an alternative charging method must be put into place.

See illustration at the end of this manual for proper positive and negative terminal connections.

CONTROL PANEL

All AMERIFLO diesel engines feature an integrated, digital AMERITOUCH human interface device (FIGURE 13). This high quality touchscreen control panel allows the user a very easy interface to control all functions of the diesel engine assembly. This control panel also communicates with the third party diesel engine fore pump controller.

The AMERITOUCH diesel engine controller and the third party fire pump controller are powered by two batteries of the same voltage. The charging system allows for the

troubleshooting when required.

Grounding lugs are clearly identified and this grounding loop extends to the panel cover.

NAMEPLATE

The AMERITOUCH control panel has a nameplate shown below. It is fitted to the exterior of the cabinet where is visible.

		125 MORRISON ROAD ROSSVILLE, TN 38066 UNITED STATES OF AMERICA
DIESEL ENGINE INSTRUMENT PANEL		
MODEL	<input type="text"/>	
SERIAL NUMBER	<input type="text"/>	
DC VOLTAGE	V	MANUFACTURE DATE
<input type="text"/>		<input type="text"/>

FIGURE 12 - CONTROL PANEL NAMEPLATE

MODEL:

Model of the control panel

SERIAL NUMBER:

Serial number of the control panel issued by Production Control

DC VOLTAGE:

Rated input power Direct Current (DC) required

MANUFACTURE DATE:

Control panel manufacture date

CONTROL PANEL OPERATIONS ALARMS

This section of the manual will detail the features of the AMERITOUCH control panel as well as how to test it's functionality while in the field.

OIL PRESSURE SENSOR OPEN ALARM

This alarm will display when the diesel engine controller oil pressure sensor measures lower than normal oil pressure. Loss of oil pressure can cause catastrophic engine damage.

WATER TEMPERATURE SENSOR OPEN ALARM

This alarm will display when the diesel engine controller detects water temperatures that are outside of the normal

operating range while the diesel engine is running.

STANDBY WATER TEMPERATURE SENSOR OPEN ALARM

This alarm will display when the diesel engine controller detects water temperatures that are outside of the normal operating range while the diesel engine is in standby (not running).

LOW STANDBY WATER TEMPERATURE SENSOR OPEN ALARM

This alarm will display when the diesel engine controller detects water temperatures that are lower than the normal operating range while the diesel engine is in standby (not running).

LOW SPEED ALARM

This alarm will display when the diesel engine controller detects a lower speed from the magnetic sensor that is outside of the normal operating range while the diesel engine is running.

GENERATOR FAULT ALARM

This alarm will display when the diesel engine controller detects a generator voltage that is outside of the normal operating range while the diesel engine is running. This generates a visual and audible alarm that can be reset after parameters return to normal.

LOW OR HIGH BATTERY VOLTAGE ALARM

This alarm will display when the diesel engine controller detects a higher or lower battery voltage that is outside of the normal operating range while the diesel engine is running. This generates a visual and audible alarm that can be reset after parameters return to normal.

LOW OIL PRESSURE ALARM

This alarm will display when the diesel engine controller detects a lower diesel engine oil pressure that is outside of the normal operating range while the diesel engine is running. This will send a signal to the third party fire pump controller (terminal 4). This generates a visual and audible alarm that can be reset after parameters return to normal.

To field test this alarm, with the diesel engine running, open the AMERITOUCH instrument panel and press the button SW1. This will create a visual and audible alarm for low diesel engine oil pressure and can be reset after parameters return to normal.

— AMERIFLO —

HIGH WATER RUNNING TEMPERATURE ALARM

This alarm will display when the diesel engine controller detects a high water temperature (internal) that is outside of the normal operating range while the diesel engine is running. This will send a signal to the third party fire pump controller (terminal 5). This generates a visual and audible alarm that can be reset after parameters return to normal.

To field test this alarm, with the diesel engine running, open the AMERITOUCH instrument panel and press the button SW2. This will create a visual and audible alarm for high water running temperature and can be reset after parameters return to normal.



WARNING - If the AMERITOUCH diesel engine controller displays a visual and/or audible alarm, use the LCD display to troubleshoot the issue.

HIGH RAW WATER RUNNING TEMPERATURE ALARM

This alarm will display when the diesel engine controller detects a high raw water temperature (external) that is outside of the normal operating range while the diesel engine is running. This will send a signal to the third party fire pump controller (terminal 310). This generates a visual and audible alarm that can be reset after parameters return to normal.

To field test this alarm, with the diesel engine in standby, heat the tee on the external cooling where the temperature sensor is located to above 104°F [40°C] making sure not to damage any system piping. This will create a visual and audible alarm for high water running temperature and can be reset after parameters return to normal.

LOW RAW WATER FLOW ALARM

This alarm will display when the diesel engine controller detects a raw water flowrate that is less than 75% or normal capacity while the diesel engine is running. This will send a signal to the third party fire pump controller (terminal 311). This generates a visual and audible alarm that can be reset after parameters return to normal.

To field test this alarm, with the diesel engine running, shut off all ball valves in the external cooling loop. This will create a visual and audible alarm for high water running temperature and can be reset after parameters return to normal.



WARNING - Once the test is complete, immediately open the ball valves so the external loop continues to supply raw water to the heat exchanger.

Make all remaining connections between the AMERITOUCH diesel engine controller and the third party diesel fire pump controller. Refer to instruction supplied by third party fire pump controller manufacturer.

Always follow the third party fire pump controller recommendations for turning on and off battery chargers and/or connecting and disconnecting batteries from the third party fire pump controller.

ENGINE SPEED ADJUSTMENTS

A mechanical governor maintains proper diesel engine speed and the speed is set at the factory. If after a field rebuild the speed needs a minor adjustment, follow the below procedure.

- Start the diesel engine normally by following the procedures in this manual.
- Allow the diesel engine to warm up.
- Loosen the jam nuts on the throttle linkage. See FIGURE 14.
- While using the AMERITOUCH diesel engine controller, observe the diesel engine speed as adjustments are made. Once finalized, tighten the jam nuts so changes are final.
- Stop the diesel engine normally by following the procedures in this manual.

ENGINE OVERSPEED SETTINGS

The overspeed setting is set at the factory to 110% of the rated speed. Do not change this setting without contacting the factory.

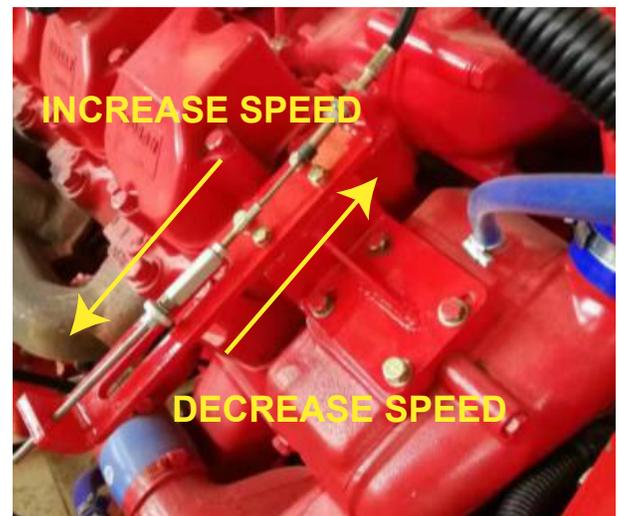

FIGURE 14 - DIESEL ENGINE SPEED CHANGES

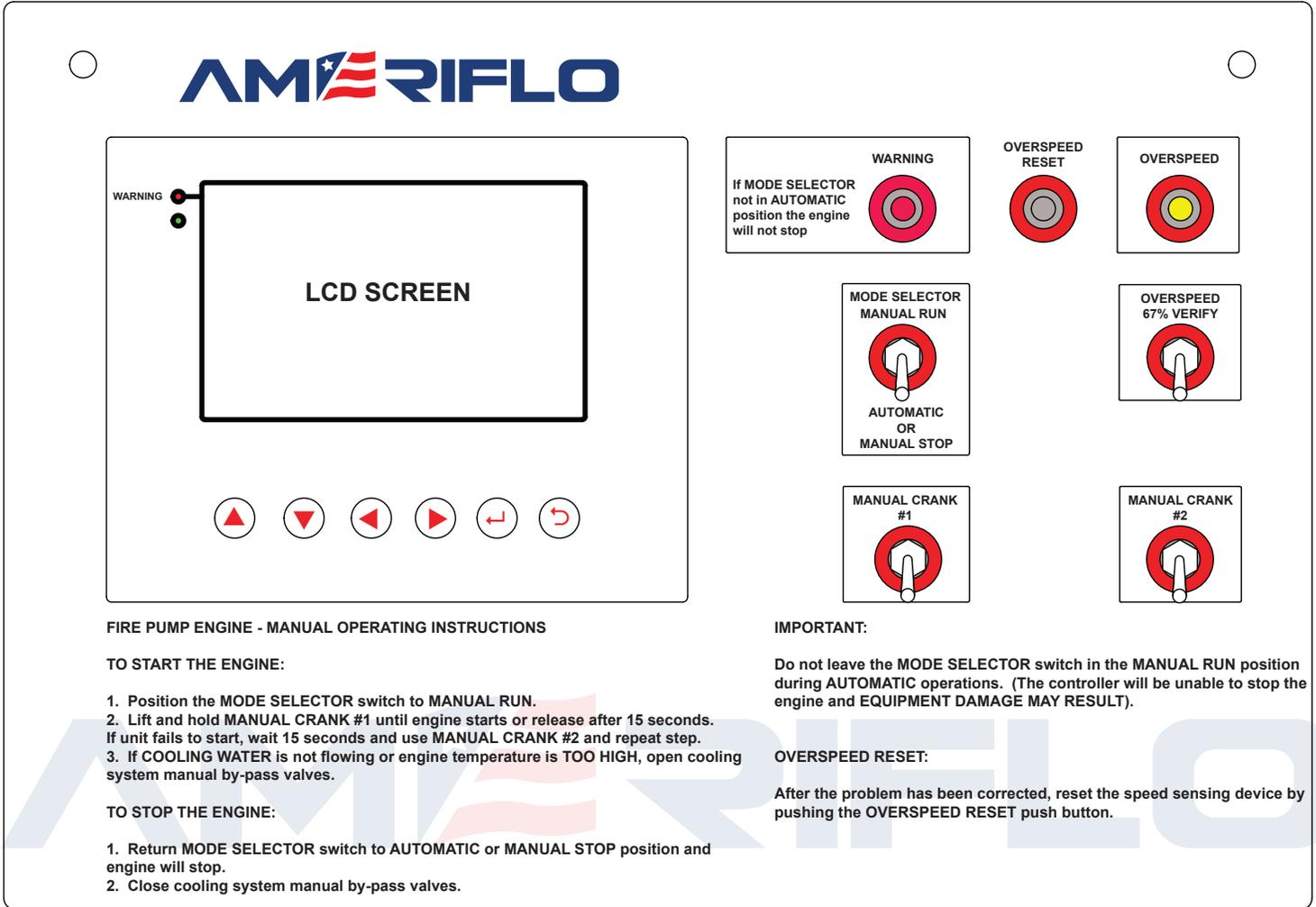

FIGURE 13 - AMERITOUCH DIESEL ENGINE CONTROLLER

ENGINE OVERSPEED TEST

To test the overspeed alarm circuit, follow the below procedure.

- Start the diesel engine normally by following the procedures in this manual.
- Allow the diesel engine to warm up.
- Press and hold the OVERSPEED TEST button on the AMERITOUCH diesel engine controller for three (3) seconds. This will send a signal to the third party fire pump controller (terminal 3).
- Press the RESET OVERSPEED button on the AMERITOUCH diesel engine controller to reset the alarm. Resetting the alarm resets the injection pump solenoid so that the diesel engine can be restarted.

OPERATION

PREPARATIONS

ADDING ENGINE OIL

Use only diesel engine fuel as indicated in Section above named LUBRICATION SYSTEM. In order to accurately to measure the oil level, follow the procedure below.

- Add oil to the diesel engine until the oil level indicates MAX on the engine dipstick. See FIGURE 11.
- All supply hoses and the external oil cooler must be filled with oil for cooling. See TABLE 8 for oil volume.

INITIAL FILL VOLUME	OIL CHANGE VOLUME (WITH FILTER)
42.3 QTS [40.0 L]	43.3 QTS [41.0 L]

TABLE 8 - OIL VOLUME

- Allow the diesel engine to run until the thermostat opens (at approximately 185°F [85°C]).
- Allow the engine to run for an additional 2 minutes.
- Turn off the engine and allow 5 minutes for the oil to drain out of the diesel engine back into the oil pan.
- Check the oil level, and if necessary, refill the level to MAX mark on the dipstick.

ADDING FUEL

Use only diesel engine fuel as indicated in Section above named FUEL SYSTEM.



DANGER - Never fill the diesel fuel tank while the diesel engine is running. Do not spill any diesel fuel and any that does spill must be cleaned up immediately. Flammable hazards can injure or cause death.

Make sure the pump room and the area around the fuel tank are clean at all times. Do not store oil soaked or fuel soaked rags in or near the diesel engine assembly.

Do not use bio-diesel fuels as these fuels can cause engine parts to seize if left for an extended period of time.

BATTERIES

Before start-up, inspect all of the batteries and all cables for damage during shipment or storage. Remove any transport straps or packaging that was present during shipment.

Prior to initial start-up, and all preparations above have been satisfied (including adding electrolyte to all batteries), run the diesel engine for about 10 minutes unloaded. During this time, check the following:

- Leaks in the coolant, oil & fuel system.
- After shutting the diesel engine down, top off oil (if necessary).
- Re-tension the drive belt(s) (if necessary).

RECONDITIONED ENGINE

If a diesel engine is being placed back into service after a major overhaul, ALL of the following must be done:

- Change the oil.
- Change the oil filter(s).
- Change the fuel filter(s).
- Change the air filter(s).
- Check the drive belt(s) and re-tension if necessary.
- Check for leaks in the coolant, oil & fuel system.
- Inspect the engine mounts and tighten if necessary.
- Check the valve clearance and adjust if necessary.

ENGINE START-UP/SHUT-DOWN

PRECAUTIONS

The procedures below will explain how to start and stop the diesel engine. See FIGURES 15 & 16 for proper position of the electronic solenoid and the knob. Make the following precautions PRIOR to engine start-up:

- When manually starting the diesel engine, make sure the cooling loop valves are open to the diesel engine heat exchanger.
- Make sure that no personnel are present around any rotating piece of equipment.



ROTATING EQUIPMENT - Severe injury and/or death can occur if all coupling guards are not properly installed PRIOR to pump startup.

- Make sure that all coupling and driveshaft guards are in place before starting diesel engine.
- If the speed governor has been removed then the engine must not be turned on for any reason.
- Do not energize the starter for more than 15 seconds. If the diesel engine fails to start, wait 60 seconds before trying again. If the diesel engine will not start after multiple attempts, discontinue and inspect the diesel engine to find the cause. Refer to the TROUBLESHOOTING section of this manual for guidance.

ADDITIONAL WORK FOR

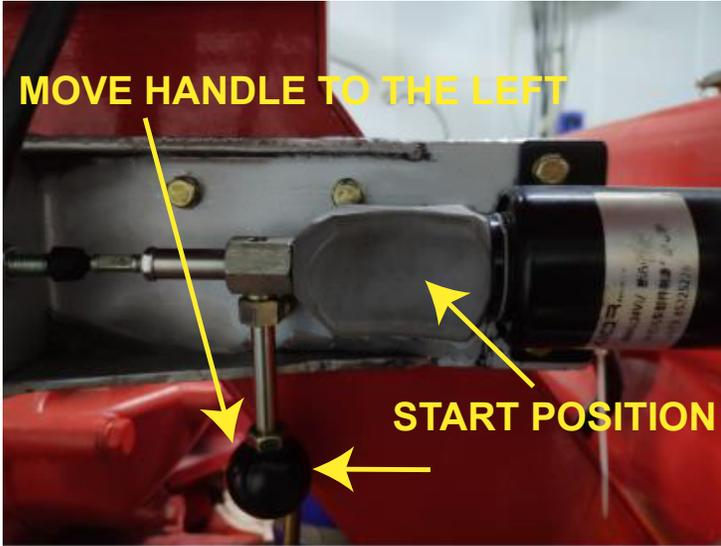

FIGURE 15 - SOLENOID RUN POSITION



FIGURE 16 - SOLENOID STOP POSITION

STARTING/STOPPING USING THE THIRD PARTY FIRE CONTROLLER

In this starting mode, the diesel engine is started by the third party fire controller. The AMERITOUCH diesel engine controller cannot start or stop the diesel engine, it only controls the speed (OVERSPEED protection), monitor diesel engine systems and display alarms & audible alarms.



WARNING - For diesel engine shutdown while the engine is running, press the red "STOP" button on the front of the third party fire pump controller or turn the selector switch on the "OFF" position (EMERGENCY STOP). Using this method to stop the diesel engine requires the switch on the AMERITOUCH diesel controller to be in the "AUTO" position.

STARTING/STOPPING USING THE AMERITOUCH DIESEL ENGINE FIRE CONTROLLER

In this starting mode, the diesel engine is started by the AMERITOUCH diesel engine fire controller (FIGURE 13). This method of starting would be used if the third party fire pump controller was inoperable for whatever reason.

- Turn the mode selector on the AMERIFLO diesel engine controller to "MANUAL". The manual mode indicator "WARNING" will illuminate.
- Lift and hold MANUAL CRANK #1 until engine starts (or release after 15 seconds).
- If diesel engine fails to start, wait 60 seconds and use MANUAL CRANK #2. Repeat the previous step.
- If coolant is not flowing or diesel engine temperature is too high, open the cooling system by-pass loop.
- Return the MODE SELECTOR switch to AUTOMATIC/MANUAL STOP position and diesel engine will shut down. Pushing the OVERSPEED VERIFICATION button will also stop the diesel engine.

STARTING/STOPPING USING THE DIESEL ENGINE BATTERY CONTACTORS

In this starting mode, the diesel engine is started by using the battery contactors located on the diesel engine. See FIGURES 15 & 16. This scenario is an EMERGENCY scenario used when the AMERITOUCH diesel engine controller and the third part fire pump controller are inoperable. To start the diesel engine, make sure the solenoid is in the correct position. See FIGURE 15. Lift

— AMERIFLO —

up on the battery contactors for a maximum of 15 seconds until the engine starts. See FIGURE 17. If the diesel engine fails to start, wait 60 seconds and repeat the process. See FIGURES 17 & 18.

To stop the diesel engine, move the solenoid to the correct position. See FIGURE 18.



FIGURE 17 - EMERGENCY START USING BATTERY CONTACTORS



FIGURE 18 - EMERGENCY STOP USING BATTERY CONTACTORS



CAUTION - If possible, do not stop the diesel engine while fully loaded. If the cooling loop manual by-pass valves were opened during manual starting, make sure the cooling loop valves are positioned back to normal operation. Do not start the diesel

engine with the third party fire pump controller when the AMERITOUCH diesel engine controller is in "MANUAL" mode.

WEEKLY TEST

The diesel engine assembly should have a weekly test run to make sure all systems are functional and a log of the event should be recorded. During this weekly test, the diesel engine can be run at reduced load. Each weekly test should not exceed 30 minutes (2 hours per month). Pre-startup and Start-up forms are located at the end of this manual and record kept in a safe place for future troubleshooting.

Before performing the weekly test, confirm the following:

- The operator has easy and quick access to the EMERGENCY STOP button on the third party fire pump controller.
- The plant room ventilation ducts are open and the engine has good ventilation for maximum performance.
- All coupling and driveshaft guards are installed.



ROTATING EQUIPMENT - Severe injury and/or death can occur if all coupling guards are not properly installed PRIOR to pump startup.

- Battery covers are in place and nothing is in or around the diesel engine that would prohibit a good start-up.
- Heat exchanger raw water is available without restriction. Monitor the water temperature and oil pressure during the weekly run test. If coolant temperature is high, check the cooling loop wye-strainers, engine coolant level, proper functioning thermostat(s) and that the heat exchanger is working properly.

TROUBLESHOOTING

The following is a guide to troubleshooting problems with AMERIFLO Pumps & Engines. Common problems are analyzed and solutions are offered. Obviously, it is impossible to cover every possible scenario. If a problem exists that is not covered by one of these examples, then contact a local AMERIFLO Engineer or Distributor/ Representative for assistance. Refer to the appropriate AMERIFLO diesel engine Installation, Operation & Maintenance manual for specific engine service and troubleshooting instructions as well as the appropriate AMERIFLO pump Installation, Operation & Maintenance manual.

TROUBLESHOOTING

DIESEL ENGINE FAILS TO START	INSUFFICIENT DIESEL ENGINE POWER	EXCESSIVE SMOKE IN THE EXHAUST	DIESEL ENGINE KNOCKING NOISE	LOW OIL PRESSURE OR NO OIL PRESSURE	DIESEL ENGINE OVERHEATING	DIESEL ENGINE OVERSPEED	POSSIBLE CAUSE	REMEDY
						☛	DIESEL ENGINE GOVERNOR MALFUNCTION	STOP ENGINE IMMEDIATELY. INSPECT AND REPAIR DIESEL ENGINE GOVERNOR.
						☛	FUEL INJECTION CONTROL ROD SEIZED	STOP ENGINE IMMEDIATELY. REPLACE FUEL INJECTION CONTROL ROD.
						☛	DIESEL FUEL PUMP SUPPLYING TOO MUCH FUEL	STOP ENGINE IMMEDIATELY. RE-ADJUST DIESEL ENGINE FUEL PUMP AND/OR REPLACE IF DAMAGED.
		☛		☛	☛	☛	EXCESSIVE OIL BEING BURNT IN COMBUSTION CHAMBER	STOP ENGINE IMMEDIATELY. CHECK AND/OR REPLACE PISTON RINGS AND CYLINDER LINERS. CONFIRM THAT PROPER DIESEL ENGINE OIL VISCOSITY IS CORRECT.



DRIVESHAFT

To service the driveshaft:

- Disconnect the negative battery cables and remove the driveshaft coupling guard.
- Rotate the driveshaft assembly so that access to the zerk fittings is possible.
- Use a hand held grease gun with NLGI #2 grease and install grease until grease is visible at each of the four cap seals. See TABLE 9 for AMERIFLO recommended greases.
- Verify that all bolting used on the driveshaft is torqued to the values located in TABLE 14 & 15.
- Reinstall the driveshaft coupling guard and re-connect the negative battery cable.

MANUFACTURER	GREASE
Chevron	SRI
CITGO	Premium Lithium EP2
Exxon	Lidok EP2
Keystone	81EP2
Pennzoil	PennLith 712
Shell	Alvania EP2
Texaco	Multifak EP2

TABLE 9 - RECOMMENDED NLGI #2 GREASES



WARNING - Use of lubricants other than those listed in TABLE 7 or their equivalent will cause reduced performance, reduced bearing life and possible catastrophic bearing failure.

COUPLING GUARDS

It is very important that all coupling guards (at the driver coupling and near the pump packing housing locations) be installed **PRIOR** to startup. Failure to do so can cause serious injury or death.



ROTATING EQUIPMENT - Severe injury and/or death can occur if all coupling guards are not properly installed **PRIOR** to pump startup.

ROUTINE MAINTENANCE CHART

A routine maintenance table is provided at the end of this manual. It covers weekly tasks as well as tasks for 6 month, 1 year and 2 year milestones.

PREVENTATIVE MAINTENANCE

The MAINTENANCE section of this manual will give the end user a complete procedure for giving the diesel engine required maintenance. There are also sub-sections that detail other important maintenance procedures that may come up during normal diesel engine operation. It is also important to note that periodically the PRE START-UP checklist should be reviewed to make sure that site conditions have not changed since the initial start-up.

NEED FOR MAINTENANCE RECORDS

It is very important that the end user keep a record of daily, weekly, monthly and yearly maintenance records. These records are important when certain milestone events that need to be performed are recorded in a central location. From these records other important information can be gathered including trending in certain data. The analysis of this data can help with future maintenance issues and also help with eliminating certain issues that may be effecting pump or driver performance. Lastly, when and if a warranty claim is ever addressed at some future date, AMERIFLO personnel will ask for all pertinent maintenance records so that they have a clear picture of what has been done to the unit.

NEED FOR CLEANLINESS

Perhaps the major cause of diesel engine failure has to do with contamination at the job site. Contamination can be in the form of moisture, dust, dirt or other foreign debris from the job site. This contamination is very harmful to the components in the diesel engine. Dust and other debris can plug air and fuel filters in diesel engine drivers.

It is very important to maintain as clean of an area as job site conditions permit. When preventative maintenance is being performed on the diesel engine, make sure this maintenance is done in a clean area as well. Do not unpack bearings until they are ready to be immediately installed. Make sure filters and engine fluids are changed per the recommended intervals. Work should be done in an area free of moisture, dust, dirt, oil or grease. Never re-use bearings, gaskets, lip seals, o-rings and filters. Only use clean towels, shop rags and other tools when performing maintenance.

— AMERIFLO — ENGINE PUMP ROOM

Before starting the diesel engine make sure that the following are checked:

- Make sure the diesel engine area is clean and that no material is present anywhere on the diesel engine.
- Confirm that no leaks are present in the oil, coolant or fuel systems.
- Make sure that all accessories are tightly fastened and that no hardware is loose.
- Check all wiring harnesses to make sure all connections are tight.
- Check the drive belt to make sure that it is attached correctly.

INTAKE SYSTEM

Inspect the complete intake system for any gaps or cracks in the air filter housing. If any housing is cracked replace with a new part. Make sure all clamps are tight. If any clamps are loose, tighten. The air intake system is designed to pull air only through the air filter, not through cracks or gaps in the housing.

CHECKING AND REPLACING THE AIR FILTER(S)

There is no maintenance available on the air filter. When it is time to replace the air filter, discard the old one. Be advised that certain AMERIFLO diesel engines have more than one air filter.



CAUTION - Do not start the diesel engine without an installed air filter(s). Doing so allows the diesel engine to use unfiltered air which could cause catastrophic damage to the diesel engine.

- Remove the clamp(s) that hold the air filter housing closed. See FIGURE 19.
- Remove and discard the old air filter.
- Install new air filter.
- Reinstall the clamp(s) that hold the air filter housing closed.

When replacing a filter on a diesel engine with two air filters, always replace both at the same time.



FIGURE 19 - AIR FILTER HOUSING

CHECKING THE FUEL TANK AND FUEL LEVEL

The fuel level in the fuel tank should always be monitored.



CAUTION - Per NFPA 25 standards, the fuel tank level must never be less than 67% of its capacity.

During the weekly test, make sure the fuel tank level is full and that all moisture is drained from the bottom of the fuel tank.

If maintenance is performed on the fuel system, bleeding air from the fuel system is required. The procedure for bleeding the fuel system is listed below.

FUEL FILTER(S)

Make sure that the fuel filter is inspected and replaced as per the ROUTING MAINTENANCE CHECKLIST at the end of this manual. The filter is of the screw on type and a filter wrench needs to be used to remove the old fuel filter. Be advised that certain AMERIFLO diesel engines have more than one fuel filter.

There is no maintenance available on the fuel filter(s). When it is time to replace the fuel filter(s), discard the old one.

REPLACING THE FUEL FILTER(S)



DANGER - Diesel engine fuel is flammable. Keep open flames away from the fuel source and do not smoke while changing

9050 AF12-128C INSTALLATION, OPERATION & MAINTENANCE MANUAL
©2021 AMERIFLO

- Close the fuel supply valve (if supplied).
- Clean the outside of the fuel filter so that the filter wrench does not slip during the removal process.
- Remove the fuel filter and discard. Make sure that none of the fuel filter o-rings are still attached to the diesel engine. Remove and discard all old fuel filter o-rings. SEE FIGURE 20.
- Clean the fuel filter flange on the diesel engine.

**FIGURE 20 - FUEL FILTER**

- Before installing the new diesel engine fuel filter, fill it with clean diesel fuel from the periphery of the fuel filter. Do not add fuel through the central core as this is the location within the fuel filter that should only have filtered diesel fuel present. If you fill from the central core, this fuel will be used by the engine and will not have been previously filtered. Make sure the fuel level is approximately 0.125 - 0.625 IN [3 - 15 MM] from the top of the fuel filter.
- Apply a thin film of oil to the o-ring(s) before installing the new fuel filter.
- Hand tighten the fuel filter until the o-ring(s) touch the fuel flange on the diesel engine. Continue to tighten with the filter wrench. **DO NOT OVERTIGHTEN.**
- Open the fuel supply valve (if supplied).
- Check for any fuel leaks.

Certain systems have more than one fuel filter. Repeat the above process for the second fuel filter (if supplied). Always replace all fuel filters at the same time.

BLEEDING THE FUEL SYSTEM

If the engine has not been started in a long time or if recent maintenance has been performed to the fuel system (filter change, injector change, fuel line change, etc.) air will have had the opportunity to enter the fuel system. Bleeding of the fuel system is required per the following instructions:

- Each of the injection pumps has a bleed screw located on the top of the housing. See FIGURE 21. Loosen this vent screw.

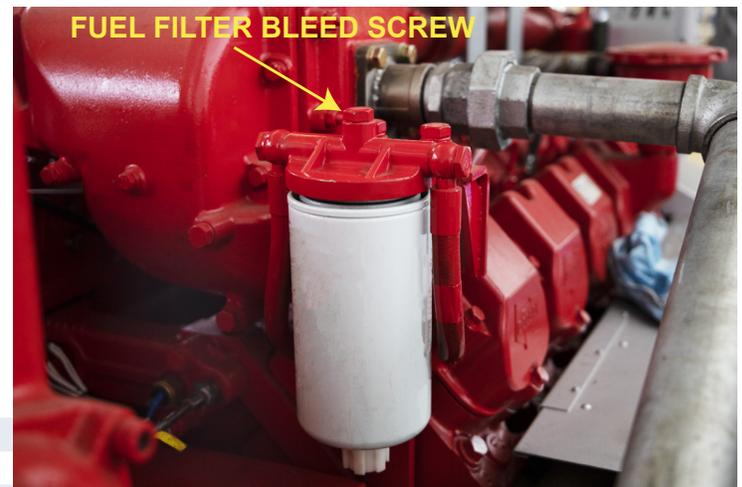
**FIGURE 21 - FUEL FILTER BLEED SCREWS**

- A small priming pump is also present on the injection pump assembly for manually priming the fuel pump assembly. See FIGURE 22. With the injection pump bleed screw loose, begin pumping the priming assembly until only fuel leaks out of the bleed screw. If bubbles are escaping the bleed screw, continue as there is still air in the system. When only diesel fuel is leaking out of the bleed screw, tighten the bleed screw.

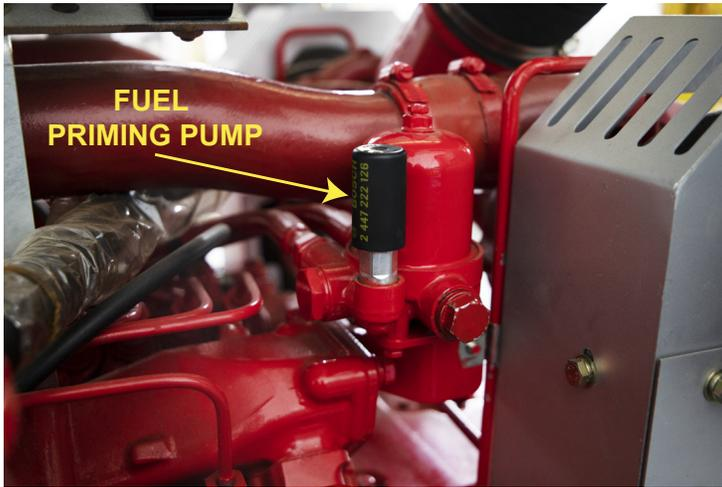

FIGURE 22 - FUEL SYSTEM PRIMING PUMP

- Certain AMERIFLO diesel engines have a bleed screw on top of the fuel filter. Use this bleed screw in a similar fashion as to the procedure above.
- To make sure that the fuel lines after the fuel injection assembly have no air present, loosen the return fuel line on the injection pump assembly. See FIGURE 23.



FIGURE 23 - FUEL RETURN LINE CONNECTION

- Begin pumping the priming assembly again until only fuel leaks out of the return fuel line. If bubbles are escaping the bleed screw, continue as there is still air in the system. When only diesel fuel is leaking out of the return fuel line, tighten the bleed screw.

CHECKING THE OIL LEVEL

The diesel engine oil level can only be accurately checked after the diesel engine has been shut down for a minimum of five (5) minutes. This time period allows for the oil to drain back into the oil pan for an accurate reading.

To check the engine oil level, do the following:

- Shut the engine off.
- Make sure the diesel engine has been shut-down for a minimum of five (5) minutes.
- Remove the dipstick. See FIGURE 24.



FIGURE 24 - OIL DIPSTICK

- Remove the dipstick and wipe with a lint free cloth. See FIGURE 25.

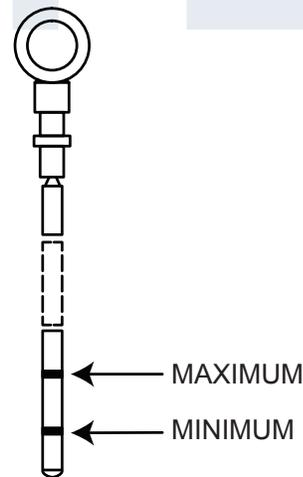

FIGURE 25 - PROPER OIL LEVEL

- Insert the dipstick fully and remove again.
- Make sure that the oil level is between the marks on the dip stick. See FIGURE 25. If the oil level is just above the ADD mark then add more oil.



CAUTION - Do not operate the diesel engine with an oil level below the minimum. Doing so can cause catastrophic diesel engine damage.

Do not attempt to check the oil while the diesel engine is running. Do not overfill the oil reservoir. Do not mix oil viscosities.

CHANGING THE DIESEL ENGINE OIL & OIL FILTER(S)

AMERIFLO uses oil with a 15W-40 viscosity as a standard. Use TABLE 10 to determine what the best viscosity of oil is recommended based on your ambient temperature.

OIL GRADE	AMBIENT TEMPERATURE	
	MINIMUM	MAXIMUM
5W-40	-40°F [-40°C]	122°F [50°C]
10W-30	-22°F [-30°C]	86°F [30°C]
10W-40	-22°F [-30°C]	104°F [40°C]
15W-40	-4°F [-20°C]	104°F [40°C]
20W-50	14°F [-10°C]	122°F [50°C]

TABLE 10 - OIL VISCOSITIES BASED ON AMBIENT TEMPERATURE

The diesel engine oil and oil filter(s) should be changed per the ROUTINE MAINTENANCE CHECKLIST or every 30 hours of diesel engine run-time. Be advised that certain AMERIFLO diesel engines have more than one oil filter.

To change the diesel engine oil, follow the below procedure:

- Turn the engine on and run until it is warm. Warm oil will allow any contaminants a better chance of being drained with the old oil versus colder, more viscous oil. The warmer oil will allow these contaminants to be suspended in the oil allowing for a more complete removal.
- Stop the diesel engine. Lock the unit out of service.



DANGER - Diesel engine oil can be extremely hot causing serious burns and injuries if allowed to contact human skin. Take appropriate safety measures.

- Remove the drain plug on the bottom of the diesel engine oil pan. See FIGURE 26.

- Clean the drain plug and use a magnet to remove any metal debris.
- Drain all diesel engine oil into a pan. Discard old oil in an environmentally friendly manner.
- Install the drain plug back into the diesel engine oil pan and tighten to 25 LB-FT [34 NM].
- Fill the oil sump up to the MAX level as indicated on the dipstick. See TABLE 11 for oil capacity for the specific diesel engine. See FIGURE 25.



FIGURE 26 - OIL DRAIN PLUG

INITIAL FILL VOLUME	OIL CHANGE VOLUME (WITH FILTER)
42.3 QTS [40.0 L]	43.3 QTS [41.0 L]

TABLE 11 - OIL CAPACITY

- Place a tray under the oil filter(s) to catch any oil that may spill when changing the oil filter(s).
- Remove the oil filter(s) using a filter wrench. Discard the old oil filter(s). See FIGURE 27.

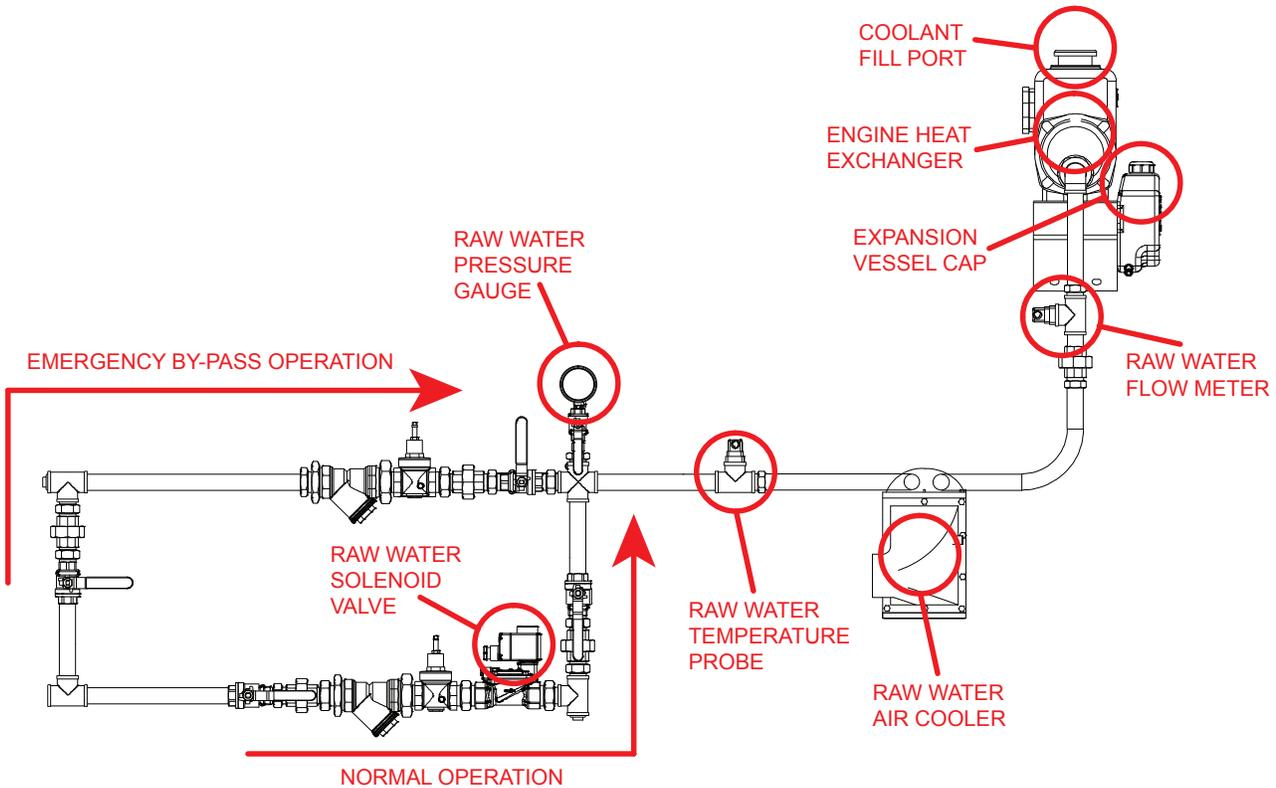

FIGURE 28 - EXTERNAL DIESEL ENGINE COOLING LOOP WITH AIR COOLER



FIGURE 27 - OIL FILTER

- Clean the oil filter flange on the diesel engine.
- Before installing the new diesel engine oil filter(s), fill it with clean oil and allow enough time for the oil to saturate the filter element.
- Apply a thin film of oil to the o-ring(s) before installing the new fuel filter(s).

- Hand tighten the fuel filter until the o-ring(s) touch the fuel flange on the diesel engine. Once hand tight, tighten an additional half turn by hand only. DO NOT OVERTIGHTEN.
- Fill diesel engine with appropriate oil (See TABLE 10) using the oil fill port on top of the engine. See FIGURE 29.
- Turn the diesel engine on and check for any oil leaks in the system.
- Turn the diesel engine off. Wait a minimum of five (5) minutes and check the diesel engine oil level. Add oil if necessary.
- Place the diesel engine unit back into service by setting the MODE SELECTOR to AUTOMATIC.

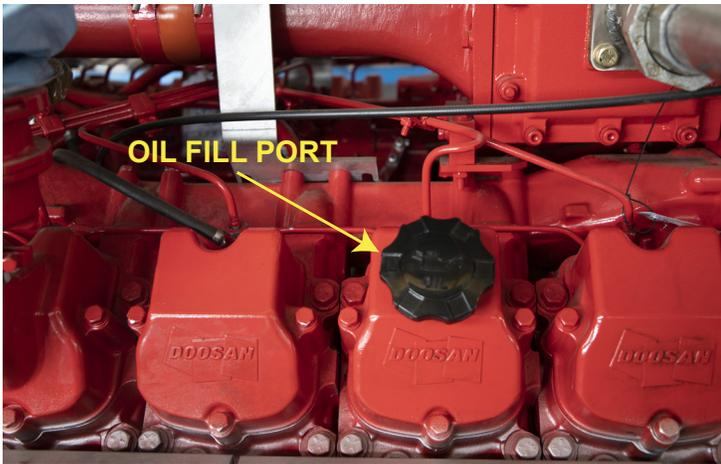

FIGURE 29 - OIL FILL CAP

CHECKING THE COOLANT LEVEL

Coolant levels must be taken while the engine is cold. Coolant in a hot engine expands and an accurate coolant level cannot be measured.

If the engine has recently run, wait at least 25 minutes before attempting to measure an accurate coolant level.



DANGER - Never remove the coolant cap while the coolant is at normal operating temperatures. Doing so could result in severe burns due to the presence of very hot, pressurized fluid.

There is no need to bleed air out of the inner diesel engine coolant loop as it is self venting. Any entrapped air within the engine will be removed with proper coolant flow.

Coolant level must be between the LOW and FULL lines as indicated on the expansion vessel mounted to the heat exchanger. See FIGURE 30.

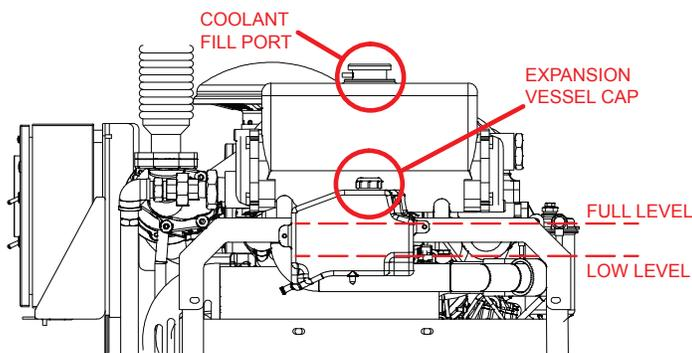

FIGURE 30 - COOLANT FILL LEVEL

Always check the coolant level PRIOR to starting the

diesel engine. If the engine is still warm or the pre-heater is on, slowly turn the pressure cap to relieve any pressure that may be trapped within the expansion vessel.

Avoid skin or eye contact with the coolant to prevent personal injury.



DANGER - Avoid skin or eye contact with the coolant to prevent personal injury. Coolant contains several corrosion inhibitors and cause injury to skin and eyes.

REPLACING COOLANT

In order to maintain a healthy cooling loop, the coolant and cooling hoses need to be replaced as indicated on the ROUTINE MAINTENANCE CHECKLIST. When replacing coolant and/or cooling hoses, a proper cleaning of the cooling system must be done.



DANGER - At operating temperature, the coolant is extremely hot and under pressure. Severe burns due to the presence of very hot, pressurized fluid can occur. Always wait for the coolant temperature to drop below 104°F [40°C] before removing the expansion vessel or heat exchanger cap. When doing so, slowly unscrew to relieve pressure in the system.

To replace the coolant, follow the below procedure:

- Turn the pre-heater off and wait for the coolant temperature to drop below 104°F [40°C].
- Disconnect the hose from the pre-heater and/or drain plug to remove all coolant from the diesel engine.
- Remove all cooling hoses from the diesel engine. Inspect all hose fittings on the diesel engine for damage and replace parts as necessary.
- Install the drain plug if previously removed.
- Install new hoses and hose clamps onto the diesel engine and make sure all connections are tight.
- Fill the system with a commercially available cleaning solution (sodium carbonate and water) to flush any debris, scale and contaminants from the inner cooling loop of the diesel engine. For each 6 gallons [23 liters] of water add 1.1 LBS [0.5 KG] of sodium carbonate.



CAUTION - Do not use a caustic cleaner as it will chemically attack aluminum parts.

- Pour the cleaning solution slowly into the cooling loop to avoid air entrainment. Add the cleaning solution until the level is at the bottom of the heat exchanger. Wait an additional 3 to 5 minutes for air to evacuate the cooling system.
- DO NOT INSTALL THE EXPANSION VESSEL CAP
- Start the diesel engine and allow to run for approximately 5 minutes. Make sure the engine temperature rises above 176°F [80°C]. Once this temperature has been established, turn off the diesel engine.
- Slowly add water to the expansion vessel until the level matches the LOW level. Wait an additional 3 to 5 minutes for air to evacuate the cooling system.
- Start the diesel engine again and allow to run for approximately 5 minutes. Make sure the engine temperature rises above 176°F [80°C]. Once this temperature has been established, turn off the diesel engine.
- Drain all fluid from the cooling system. If the fluid is excessively dirty, repeat the above process until the flushed fluid is clean and free of debris.
- Make sure the cooling hoses are connected and tight to the pre-heater.
- Fill the cooling system with coolants meeting ASTM D-4985 or GB24973 requirements. Wait an additional 3 to 5 minutes for air to evacuate the cooling system.



WARNING - A 50% water and 50% ethylene solution is required for all diesel engine operations. Pre-mix the mixture before installation to prevent pure ethylene from coming into contact with certain diesel engine components.

This will prevent possible chemical attack of certain diesel engine components.

Do not use a mixture of ethylene glycol and propylene glycol. Use one or the other only at a single time. Do not use coolants with nitrates present as this can cause damage to the diesel engine. AMERIFLO recommends a coolant that meets ASTM D-4985 or GB24973 requirements. See TABLE 12 for coolant volume.

Do not use a concentration of glycol over 70% as it offers

an inferior heat transfer ability, adverse freezing protection and a possible silicate dropout. Concentrations below 30% offer little freezing protection, boiling of the coolant in the inner loop and little corrosion protection to the diesel engine.



WARNING - Do not use automotive type coolants (i.e. to ASTM D3-3306) in AMERIFLO diesel engines. These coolants do not have the proper additives to protect heavy-duty diesel engines and may damage the diesel engine and/or cooling loop.

DIESEL ENGINE	COOLANT CAPACITY QUARTS [LITERS]
AF12-128C	71.9 [68]

TABLE 12 - COOLANT VOLUME

Coolant inhibitors are also recommended by AMERIFLO to resist corrosion, cavitation protection, to maintain proper pH levels and to prevent the formation of scale. Inhibitors become depleted over time so the addition of coolant inhibitors is needed to maintain proper strength levels. TABLE 13 shows proper coolant inhibitor strength levels.

INHIBITOR	MINIMUM PARTS PER MILLION	MAXIMUM PARTS PER MILLION
BORON (B)	1000	1500
NITRITE (NO ₂)	800	2400
NITRATES (NO ₃)	1000	2000
SILICON (SI)	50	250
PHOSPHOROUS (P)	300	500
PH LEVEL	8.5	10.5

TABLE 13 - COOLANT INHIBITOR LEVELS

Contact AMERIFLO for coolant inhibitor kits to properly measure coolant inhibitor levels.

The diesel engine thermostat will initially remain closed after the engine starts up. The internal coolant loop will not be active until the thermostat opens up. At that time, the water pump will circulate coolant through the heat exchanger and back to the diesel engine. If the coolant temperature drops the thermostat will close and the loop will remain non-active until a future temperature rise. See FIGURE 7.

- Install the pressure cap onto the expansion chamber.
- Start the diesel engine and allow to run for approximately 5 minutes. Make sure the engine

DATE **APRIL 2021**

temperature rises above 176°F [80°C]. Once this temperature has been established, turn off the diesel engine and check the cooling loop for leaks. Address leaks as necessary.

- Let the diesel engine cool to below 104°F [40°C] and then slowly open the pressure cap to recheck coolant level. Add coolant as required to maintain the proper level.

BATTERIES

CLEANING

Keep the batteries, cables and connectors clean at all times. AMERIFLO diesel engines use a 24 volt, negative ground system.

To clean the battery posts, follow the procedure below:

- Loosen the battery cable clamp bolts and remove from the battery post.
- Clean the battery cables and battery posts to remove any buildup and/or corrosion.
- Grease the battery posts with an acid-free and acid-resistant grease.
- Place the battery clamps back onto the battery posts, ensuring good contact.
- Tighten hardware to hand-tight so future service can be maintained.

ELECTROLYTE LEVELS



DANGER - If sulfuric acid makes direct contact with the eyes, it can cause permanent blindness. If ingested, this chemical may cause internal burns, irreversible organ damage, and possibly death. Exposure to sulfuric acid aerosols at high concentrations leads to severe eye and respiratory tract irritation and tissue damage.



DANGER - Gasses emitted by wet cell batteries can be explosive! Keep open sparks and flames away from batteries at all times.

Electrolyte is not shipped with the batteries and is supplied by others. Once the electrolyte has been added to the batteries, a minimum of 24 hours of charging time is required before diesel engine start. Follow the battery manufacturers instruction as to the type and concentration of electrolyte needed.

To fill the batteries with electrolyte, follow the below procedure:

- Check electrolyte levels prior to starting the diesel engine.
- Remove the battery fill caps and add electrolyte to the bottom of each port.
- Install the battery caps.

DRIVE BELT

DRIVE BELT GUARD



ROTATING EQUIPMENT - Severe injury and/or death can occur if all coupling guards are not properly installed PRIOR to pump startup.

ALWAYS check the belt tension with the diesel engine locked out of service. ALWAYS change a drive belt ONLY when the diesel engine is locked out of service.

After servicing the drive belt ALWAYS reinstall the drive belt guard PRIOR to returning the diesel engine back to service.

CHANGING THE DRIVE BELT(S)

When inspecting the drive belt for wear, make sure that a complete inspection can be done. Transverse cracks that are along the width of the drive belt are acceptable. Longitudinal cracks that are along the length of the drive belt are not acceptable.

If any wear or abrasion is visible, discard and replace the drive belt.

To replace the drive belt, follow the below procedure:

- Turn off and lockout the diesel engine.
- Remove the drive belt guard.
- Rotate the drive belt tensioner in the clockwise direction and remove the drive belt. With the drive belt removed, rotate the drive belt tensioner pulley to check for smooth rotation, any radial or axial movement and/or any wear on the pulley itself. If the drive belt tensioner is damaged, discard and replace.
- Remove and discard the old drive belt.
- Rotate the drive belt tensioner in the counter-clockwise direction and install a new drive belt.

- Check the drive belt tension to make sure it is within factory tolerances.



CAUTION - Proper drive belt tension is very important. Press on the drive belt in the middle of two pulleys with a force of 9 LBF [39 N]. The drive belt should not deflect more than 0.625 in [15 mm].

- Install the drive belt guard.
- Run the engine for 15 minutes after the new drive belt is installed and then turn off the engine.
- Recheck the drive belt tension. If the tension is within above guidelines then the procedure is finished. If the drive belt tension is incorrect, repeat the process.

For AMERIFLO diesel engines that have more than one drive belt, replace all drive belts at the same time.

CHECKING THE DRIVE BELT TENSION

Checking the belt tension is very important for drive belt longevity. A drive belt that does not have the proper tension may slip on the drivetrain and in certain cases not allow the alternator to recharge the batteries correctly. The drive belt also powers the diesel engine water pump and a drive belt that slips may not allow the water pump to flow the correct amount of fluid.



CAUTION - Proper drive belt tension is very important. Press on the drive belt in the middle of two pulleys with a force of 9 LBF [39 N]. The drive belt should not deflect more than 0.625 in [15 mm].

To adjust the drive belt tension, follow the procedure below:

- Turn off and lockout the diesel engine.
- Remove the drive belt guard.
- Loosen the bolts that hold the alternator in position. The alternator has a slotted bracket and tension nuts that will release the tension on the drive belt. See FIGURE 31.
- Re-tension the drive belt by moving the alternator back into position and tightening the bolts to secure the alternator into position.
- Install the drive belt guard.
- Run the engine for 15 minutes after the drive belt is re-tensioned and then turn off the engine.

- Recheck the drive belt tension. If the tension is within above guidelines then the procedure is finished. If the drive belt tension is incorrect, repeat the process.

CHECKING THE DRIVE BELT TENSIONER

Rotate the drive belt tensioner in the clockwise direction and remove the drive belt. With the drive belt removed, rotate the drive belt tensioner pulley to check for smooth rotation, any radial or axial movement and/or any wear on the pulley itself. If the drive belt tensioner is damaged, discard and replace.

Rotate the drive belt tensioner in the counter-clockwise direction and re-install the drive belt. Make a visual inspection that the drive belt centerline is in alignment with the other pulleys. See FIGURE 31.

CHECKING THE ALTERNATOR



CAUTION - Never disconnect any wiring between the battery, alternator and voltage regulator while the diesel engine is running.

If it becomes necessary to operate the diesel engine without connection to the batteries, disconnect the voltage regulator from the alternator BEFORE starting the diesel engine.

When routing battery cables, make sure the positive and negative terminals are clearly marked and only connected to the correct connections.

If the diesel engine is to be washed down make sure that the voltage regulator and alternator are protected from moisture.

Be very careful to not short live wires to ground. Do not ground to the engine if welding on the base. Ground directly to the metal being welded.

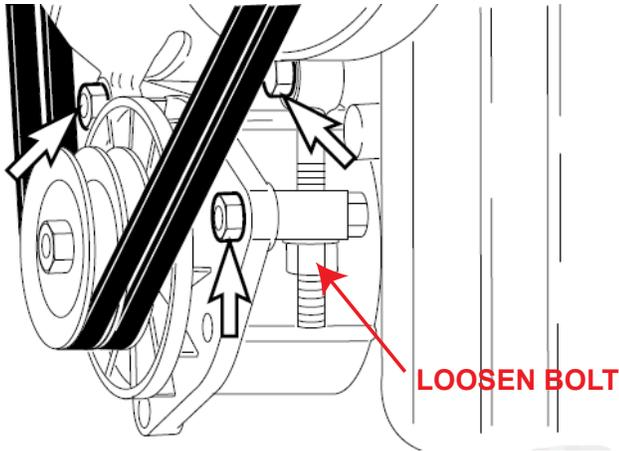

FIGURE 31 - DIESEL ENGINE DRIVE BELT

BOLT SIZE		TIGHTENING TORQUE	
METRIC	STANDARD	LB-FT	N-M
4 MM	5/32 IN	2.7	3.6
5 MM	3/16 IN	5.2	7.0
6 MM	1/4 IN	8.9	12.0
7 MM	9/32 IN	14.6	19.8
8 MM	5/16 IN	21.8	29.6
9 MM	11/32 IN	28.0	38.0
10 MM	3/8 IN	38.7	52.5
12 MM	1/2 IN	65.6	89.0
14 MM	9/16 IN	99.6	135
16 MM	5/8 IN	151	205
18 MM	11/16 IN	190	257
20 MM	3/4 IN	264	358
22 MM	7/8 IN	321	435
24 MM	15/16 IN	411	557

TABLE 14 - CAPSCREW & NUT TIGHTENING TORQUE RATINGS

SET SCREW SIZE		TIGHTENING TORQUE	
METRIC	STANDARD	LB-FT	N-M
≤ 9.50 MM	≤ 0.375 IN	22.75	30.70
> 12.70 MM	> 0.500 IN	51.25	69.16

TABLE 15 - PUMP COMPANION FLANGE SET SCREW TORQUE VALUES

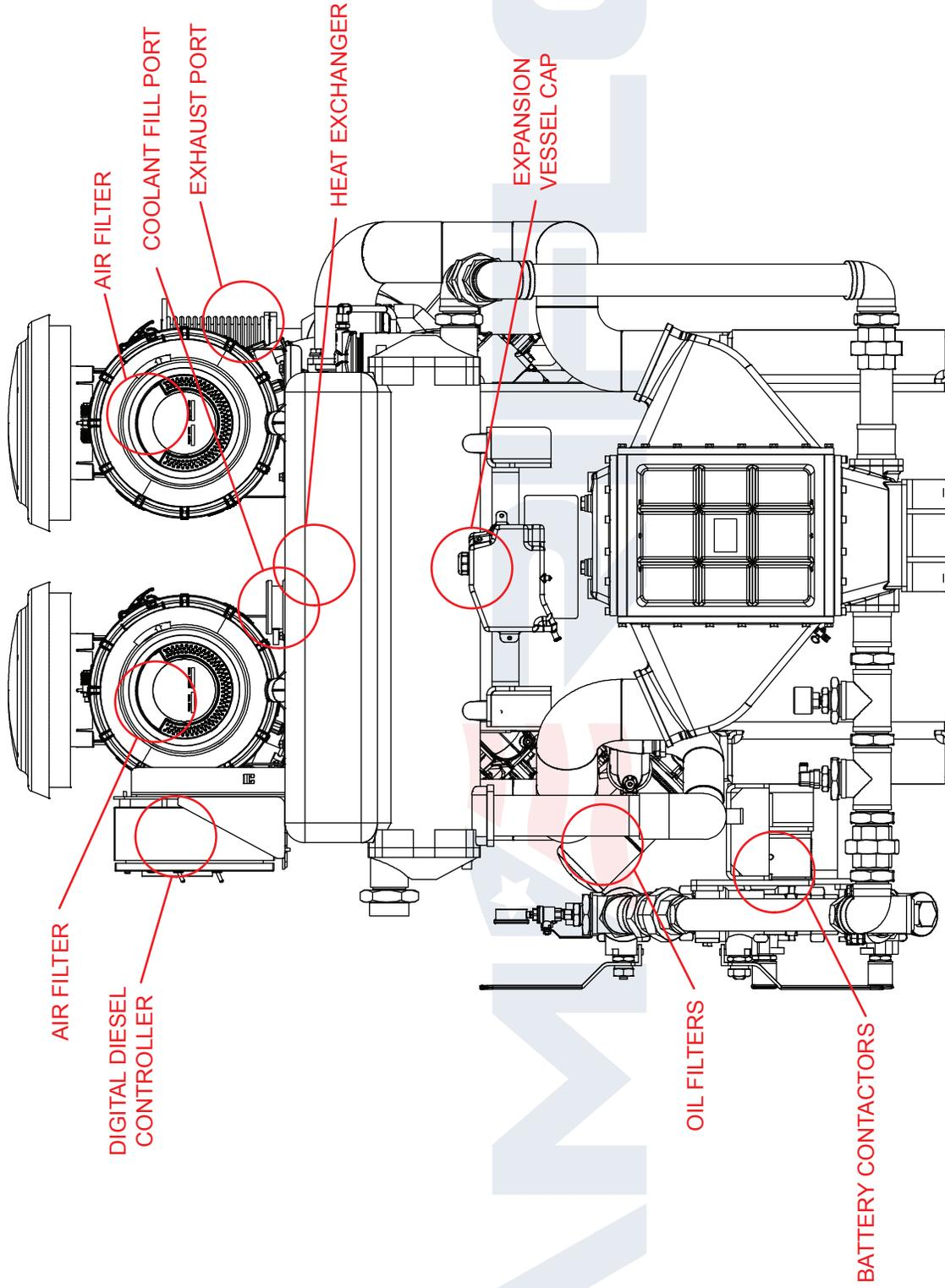

NOTES:
1. ALL PLUMBING MUST BE SUPPORTED AND/OR ISOLATED SO THAT NO WEIGHT OR STRESS IS APPLIED TO ANY ENGINE COMPONENT.
2. REFER TO SPECIFIC MODELS' INSTALLATION, OPERATION & MAINTENANCE MANUAL FOR INSTALLATION GUIDELINES.

		NAME: INSTALLATION DRAWING DIESEL ENGINE DRIVEN MODEL: AF12-128C		PROJECTION:			
		PART NO.: AF12-128C-FRONT		PROJECT:			
REV	UNITS	DATE	DATE	DATE	SCALE	PAGE	OF
	IN/MM	09/01/2020	09/01/2020	09/01/2020	NONE	1	1
		M.J.F.	M.J.F.	M.J.F.			
A		CREATION	DESCRIPTION	APVD			
REV							

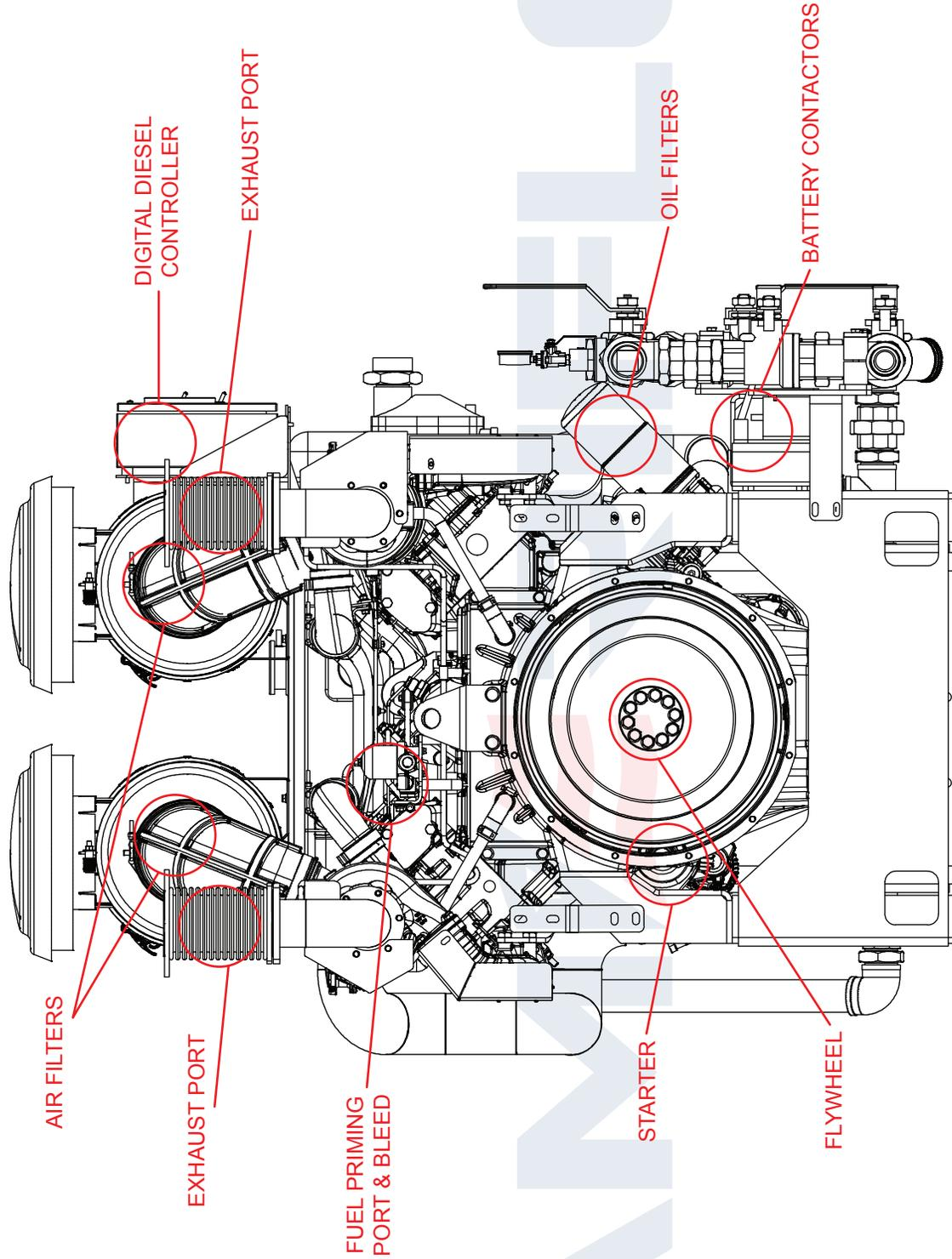

NOTES:

1. ALL PLUMBING MUST BE SUPPORTED AND/OR ISOLATED SO THAT NO WEIGHT OR STRESS IS APPLIED TO ANY ENGINE COMPONENT.
2. REFER TO SPECIFIC MODELS' INSTALLATION, OPERATION & MAINTENANCE MANUAL FOR INSTALLATION GUIDELINES.

REV	UNITS (IN/MM)	AMERIFLO	NAME	DATE	DATE	DATE	DATE	DATE	DATE	DATE	SCALE	PAGE	OF
			INSTALLATION DRAWING	09/01/2020							NONE	1	1
			DIESEL FIRE PUMP DRIVER	M.J.F.									
			MODEL AF12-128C	CHK BY:	DATE:								
				09/01/2020	M.J.F.	DWN	APVD						
A				CREATION									
REV				DESCRIPTION									

FLYWHEEL HOUSING SAE #1

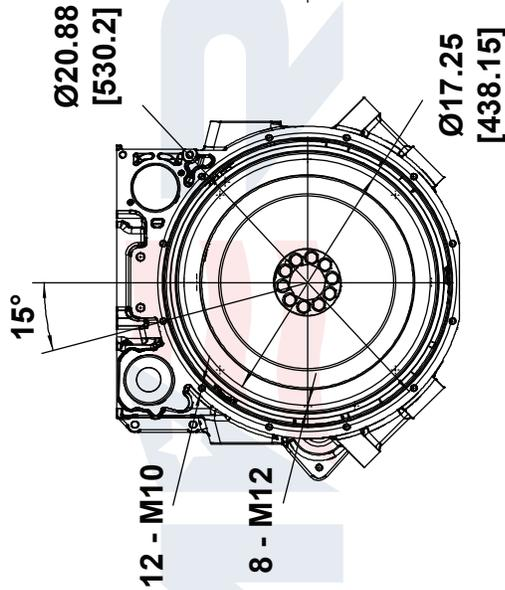

FLYWHEEL 14.00

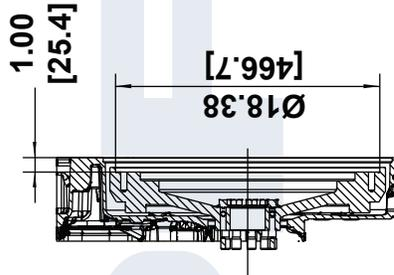

- NOTES:**
1. ALL PLUMBING MUST BE SUPPORTED AND/OR ISOLATED SO THAT NO WEIGHT OR STRESS IS APPLIED TO ANY ENGINE COMPONENT.
 2. REFER TO SPECIFIC MODELS' INSTALLATION, OPERATION & MAINTENANCE MANUAL FOR INSTALLATION GUIDELINES.

REV	UNITS (IN/MM)	SCALE	PAGE	OF
A		NONE	1	1

NAME:	INSTALLATION DRAWING DIESEL ENGINE M/D DRIVER MODEL AF12-128C	PROJECTION:	1 st ANGLE
DRW BY:	MJF	DATE:	09/01/2020
CHK BY:	MJF	DATE:	09/01/2020
APPROVED:		DATE:	
PART NO.:	AF12-128C-FLYWHEEL	MATERIAL:	

AMERIFLO
DIESEL ENGINE BATTERIES, RACKS & CABLES
AMERIFLO DIESEL ENGINES

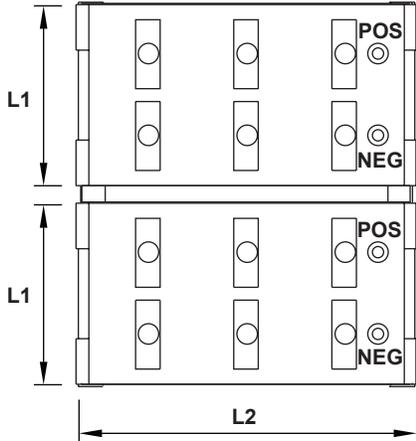

- NOTES:**
- ❶ ALL DIMENSIONS ARE IN INCHES [MM] AND MAY VARY ± 0.375 INCHES.
 - ❷ BATTERIES ARE 12 VOLT, LEAD-ACID TYPE 8-8D. APPROXIMATELY 95 POUNDS DRY, EACH.
 - ❸ BATTERIES ARE SHIPPED DRY. ELECTROLYTE (APPROXIMATELY 19 QUARTS PER BATTERY) MUST BE PROCURED LOCALLY.
 - ❹ REFER TO GENERAL ARRANGEMENT DRAWING "DIESEL BATTERIES & CABLE DIAGRAM) FOR PROPER 24 VOLT CABLE DIAGRAM.
 - ❺ BATTERY RACKS ARE FABRICATED STEEL AND WEIGH APPROXIMATELY 20 POUNDS EACH.
 - ❻ EACH BATTERY RACK HOLDS TWO BATTERIES. RACKS ARE NOT TO BE STACKED.
 - ❼ THIS DRAWING IS NOT TO BE USED FOR CONSTRUCTION UNLESS CERTIFIED BY AMERIFLO.

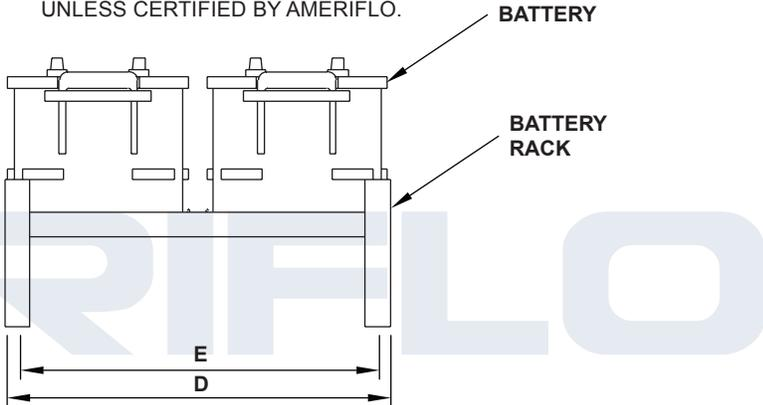
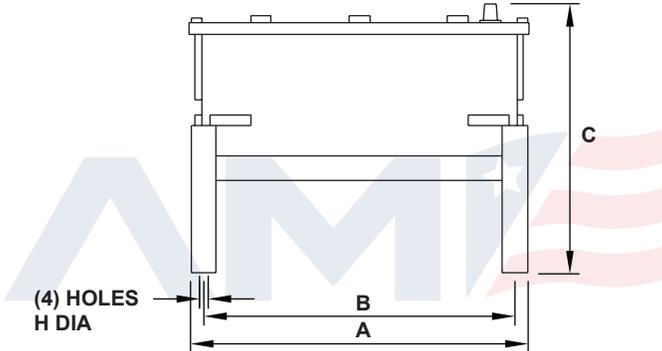

BATTERY CAPACITY	A	B	C	D	E	H	L1	L2
80AH	26.00 [660]	24.44 [620]	15.00 [380]	15.38 [390]	13.75 [350]	0.50 [14]	6.60 [168]	11.13 [283]
100AH	33.88 [860]	32.25 [820]					8.00 [203]	13.00 [330]
120AH							6.75 [171]	13.00 [330]
150AH	41.75 [1060]	40.19 [1020]	18.13 [460]	16.50 [420]	8.00 [203]	15.00 [381]		
180AH			18.88 [480]	17.38 [440]	8.00 [203]	16.00 [406]		
200AH			23.25 [590]	21.63 [550]	8.00 [203]	20.00 [508]		

- NOTES:**
- ❶ ALL CABLES ARE SAE J55BA TYPE SGT WITH TENSILE ATTACHMENT OF 700-800 POUNDS.
 - ❷ POSITIVE AND NEGATIVE CABLES ARE 60 INCHES [1524 MM] AND ARE 2/0 GAUGE OR POSITIVE AND NEGATIVE CABLES ARE 80 INCHES [2032 MM] AND ARE 3/0 GAUGE.
 - ❸ TERMINAL CLAMPS HAVE STEEL REINFORCED INSERTS.

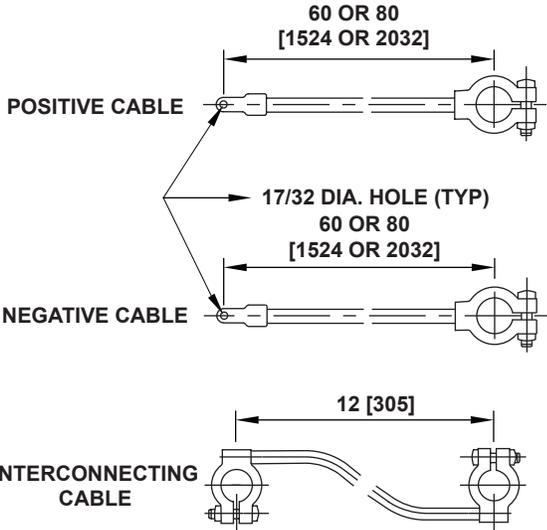

DATE APRIL 2021

DIESEL ENGINE BATTERY CABLE DIAGRAM

AMERIFLO DIESEL ENGINES

24 VOLT NEGATIVE
GROUND SYSTEM

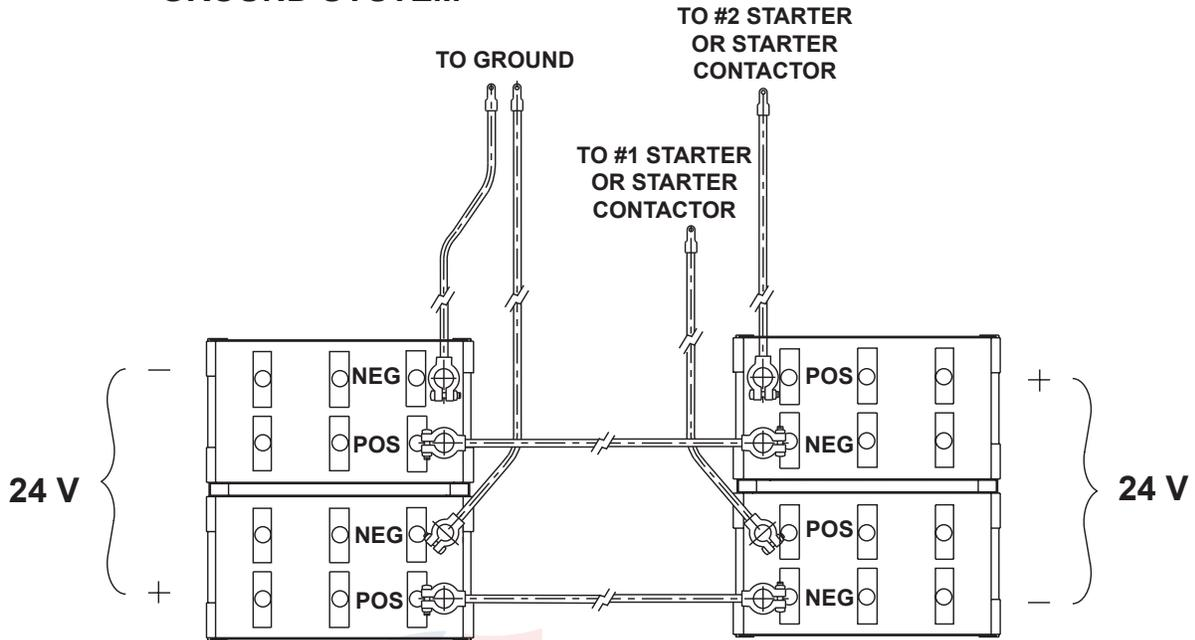

24 VOLT SYSTEM CONSISTS OF:

- (2) BATTERY RACKS
- (4) BATTERIES
- (2) POSITIVE CABLES
- (2) NEGATIVE CABLES
- (2) INTERCONNECTING CABLES

THIS DRAWING IS NOT TO BE USED FOR CONSTRUCTION UNLESS CERTIFIED BY AMERIFLO.

PRESTART-UP CHECKLIST (DIESEL ENGINES)

AMERIFLO REPRESENTATIVE: _____
 CONTRACTOR: _____
 PROJECT ENGINEER: _____
 PROJECT NAME: _____

REP PHONE NUMBER: _____
 CONTRACTOR PHONE NUMBER: _____
 ENGINEER PHONE NUMBER: _____
 PUMP LOCATION: _____

EQUIPMENT INFORMATION

PUMP MODEL: _____ PUMP S/N: _____ ESF:
 ENGINE MODEL: _____ ENGINE S/N: _____ ESV:
 GEAR MODEL: _____ GEAR S/N: _____ SCF:
 VTP:

PROCEDURE	YES	NO	N/A	COMMENTS
1. SHIPMENT				
WAS THERE ANY DAMAGE DURING SHIPMENT?	<input type="checkbox"/>	<input type="checkbox"/>	<input type="checkbox"/>	
2. STORAGE				
HAS EQUIPMENT BEEN PROTECTED FROM THE WEATHER?	<input type="checkbox"/>	<input type="checkbox"/>	<input type="checkbox"/>	
WAS EQUIPMENT SUBJECT TO DAMAGE IN STORAGE?	<input type="checkbox"/>	<input type="checkbox"/>	<input type="checkbox"/>	
3. INSTALLATION				
IOM MANUAL COMPLETELY READ AND UNDERSTOOD?	<input type="checkbox"/>	<input type="checkbox"/>	<input type="checkbox"/>	
IS GROUTING UNDER BASE PROPERLY COMPACTED?	<input type="checkbox"/>	<input type="checkbox"/>	<input type="checkbox"/>	
IS GROUT OF THE NON-SHRINK TYPE?	<input type="checkbox"/>	<input type="checkbox"/>	<input type="checkbox"/>	
HAVE PROPER ANCHOR BOLTS BEEN USED?	<input type="checkbox"/>	<input type="checkbox"/>	<input type="checkbox"/>	
BATTERIES SERVICED AND CHARGED FOR AT LEAST 24 HOURS AND PROPERLY CONNECTED TO DIESEL ENGINE?	<input type="checkbox"/>	<input type="checkbox"/>	<input type="checkbox"/>	
ARE COOLING LINES CONNECTED PROPERLY BETWEEN PUMP AND DIESEL ENGINE?	<input type="checkbox"/>	<input type="checkbox"/>	<input type="checkbox"/>	
CONFIRM COOLING WATER BY-PASS SOLENOID OPERATION?	<input type="checkbox"/>	<input type="checkbox"/>	<input type="checkbox"/>	
CONFIRM COOLING LOOP VALVES ARE IN PROPER POSITION?	<input type="checkbox"/>	<input type="checkbox"/>	<input type="checkbox"/>	
ARE ALL SAFETY GUARDS INSTALLED PROPERLY?	<input type="checkbox"/>	<input type="checkbox"/>	<input type="checkbox"/>	
EXHAUST SYSTEM PROPERLY SIZED, ROUTED AND SUPPORTED?	<input type="checkbox"/>	<input type="checkbox"/>	<input type="checkbox"/>	
DIESEL ENGINE COOLING SYSTEM FILLED TO PROPER LEVEL WITH 50% - 50% MIXTURE?	<input type="checkbox"/>	<input type="checkbox"/>	<input type="checkbox"/>	
DIESEL ENGINE OIL ADDED AND PROPER LEVEL LEVEL CERTIFIED?	<input type="checkbox"/>	<input type="checkbox"/>	<input type="checkbox"/>	
FUEL TANK DRAINED OF ALL MOISTURE AND SEDIMENT?	<input type="checkbox"/>	<input type="checkbox"/>	<input type="checkbox"/>	
FUEL LINES CONNECTED PROPERLY (BOTH SUPPLY & RETURN)?	<input type="checkbox"/>	<input type="checkbox"/>	<input type="checkbox"/>	
FUEL TANK FILLED WITH CLEAN #2 DIESEL FUEL?	<input type="checkbox"/>	<input type="checkbox"/>	<input type="checkbox"/>	
FUEL SYSTEM PROPERLY BLED?	<input type="checkbox"/>	<input type="checkbox"/>	<input type="checkbox"/>	
IS ALL WIRING CONNECTED PROPERLY AND CHECKED FOR VOLTAGE, PHASE, FREQUENCY, ETC.?	<input type="checkbox"/>	<input type="checkbox"/>	<input type="checkbox"/>	
ENGINE PRE-HEATER CONNECTED WITH PROPER AC POWER?	<input type="checkbox"/>	<input type="checkbox"/>	<input type="checkbox"/>	
AIR FILTER INSTALLED AND PROPER PUMP ROOM VENTILATION CONFIRMED?	<input type="checkbox"/>	<input type="checkbox"/>	<input type="checkbox"/>	

CUSTOMER'S REPRESENTATIVE WITNESSING START-UP:		AMERIFLO REPRESENTATIVE WITNESSING START-UP:	
NAME:	DATE:	NAME:	DATE:

START-UP CHECKLIST (DIESEL ENGINES)

AMERIFLO REPRESENTATIVE: _____
 CONTRACTOR: _____
 PROJECT ENGINEER: _____
 PROJECT NAME: _____

REP PHONE NUMBER: _____
 CONTRACTOR PHONE NUMBER: _____
 ENGINEER PHONE NUMBER: _____
 PUMP LOCATION: _____

EQUIPMENT INFORMATION

PUMP MODEL: _____ PUMP S/N: _____ ESF:
 ENGINE MODEL: _____ ENGINE S/N: _____ ESV:
 GEAR MODEL: _____ GEAR S/N: _____ SCF:
 VTP:

DESIGN CONDITIONS

FLOW: _____ RPM: _____ VOLTAGE: _____
 PRESSURE: _____ HP: _____ PHASE: _____

PROCEDURE

PROCEDURE	YES	NO	N/A	COMMENTS
1. PRESTART-UP				
HAS THE PROCEDURE CHECKLIST FOR PRE-START-UP BEEN COMPLETED?	<input type="checkbox"/>	<input type="checkbox"/>	<input type="checkbox"/>	
2. OPERATIONAL CHECKS				
MANUAL START AT DIESEL ENGINE PANEL AND PUMP CONTROLLER IN OFF POSITION?	<input type="checkbox"/>	<input type="checkbox"/>	<input type="checkbox"/>	
MANUAL START AT PUMP CONTROLLER AND DIESEL ENGINE CONTROLLER IN AUTOMATIC POSITION?	<input type="checkbox"/>	<input type="checkbox"/>	<input type="checkbox"/>	
COOLING LOOP SOLENOID OPERATION & RAW WATER DISCHARGE CONFIRMED?	<input type="checkbox"/>	<input type="checkbox"/>	<input type="checkbox"/>	
COOLING LOOP PRESSURE GAUGE WORKING?	<input type="checkbox"/>	<input type="checkbox"/>	<input type="checkbox"/>	_____ PSI
DIESEL ENGINE PANEL OPERATING CORRECTLY?	<input type="checkbox"/>	<input type="checkbox"/>	<input type="checkbox"/>	
NO LEAKS (FUEL, COOLANT, WATER, EXHAUST)?	<input type="checkbox"/>	<input type="checkbox"/>	<input type="checkbox"/>	
HIGH COOLANT TEMPERATURE ALARM VERIFICATION?	<input type="checkbox"/>	<input type="checkbox"/>	<input type="checkbox"/>	
LOW COOLANT TEMPERATURE ALARM VERIFICATION?	<input type="checkbox"/>	<input type="checkbox"/>	<input type="checkbox"/>	
LOW OIL PRESSURE ALARM VERIFICATION?	<input type="checkbox"/>	<input type="checkbox"/>	<input type="checkbox"/>	
HIGH RAW WATER TEMPERATURE ALARM VERIFICATION?	<input type="checkbox"/>	<input type="checkbox"/>	<input type="checkbox"/>	
LOW RAW WATER FLOW ALARM VERIFICATION?	<input type="checkbox"/>	<input type="checkbox"/>	<input type="checkbox"/>	
USING AN INFERAMETER, MEASURE DIESEL ENGINE EXHAUST TEMPERATURE AT FULL LOAD?	<input type="checkbox"/>	<input type="checkbox"/>	<input type="checkbox"/>	_____ °F OR _____ °C
ENGINE SPEED IS CORRECT?	<input type="checkbox"/>	<input type="checkbox"/>	<input type="checkbox"/>	
OVERSPEED SHUTDOWN VERIFICATION PROCEDURE?	<input type="checkbox"/>	<input type="checkbox"/>	<input type="checkbox"/>	
COOLING LOOP Y-STRAINERS CLEAN AFTER ALL TESTING COMPLETE?	<input type="checkbox"/>	<input type="checkbox"/>	<input type="checkbox"/>	
FINAL HOUR METER READING AFTER TESTING?	<input type="checkbox"/>	<input type="checkbox"/>	<input type="checkbox"/>	_____ HOURS

CUSTOMER'S REPRESENTATIVE WITNESSING START-UP:		AMERIFLO REPRESENTATIVE WITNESSING START-UP:	
NAME: _____	DATE: _____	NAME: _____	DATE: _____

ROUTINE MAINTENANCE CHECKLIST (DIESEL ENGINES)

AMERIFLO REPRESENTATIVE: _____	REP PHONE NUMBER: _____
CONTRACTOR: _____	CONTRACTOR PHONE NUMBER: _____
PROJECT ENGINEER: _____	ENGINEER PHONE NUMBER: _____
PROJECT NAME: _____	PUMP LOCATION: _____

EQUIPMENT INFORMATION

PUMP MODEL: _____	PUMP S/N: _____	ESF: <input type="checkbox"/>
ENGINE MODEL: _____	ENGINE S/N: _____	ESV: <input type="checkbox"/>
GEAR MODEL: _____	GEAR S/N: _____	SCF: <input type="checkbox"/>
		VTP: <input type="checkbox"/>

PROCEDURE	YES	NO	N/A	COMMENTS
WEEKLY				
CHECK AIR CLEANER(S)	<input type="checkbox"/>	<input type="checkbox"/>	<input type="checkbox"/>	
CHECK BATTERIES	<input type="checkbox"/>	<input type="checkbox"/>	<input type="checkbox"/>	
CHECK DRIVE BELT(S) & PROPER DRIVE BELT TENSION	<input type="checkbox"/>	<input type="checkbox"/>	<input type="checkbox"/>	
CHECK COOLANT HOSES	<input type="checkbox"/>	<input type="checkbox"/>	<input type="checkbox"/>	
CHECK COOLANT LEVELS	<input type="checkbox"/>	<input type="checkbox"/>	<input type="checkbox"/>	
CHECK COOLING LOOP VALVE POSITIONS	<input type="checkbox"/>	<input type="checkbox"/>	<input type="checkbox"/>	
CHECK COOLING RAW WATER SOLENOID VALVE	<input type="checkbox"/>	<input type="checkbox"/>	<input type="checkbox"/>	
CHECK COOLING RAW WATER DISCHARGE	<input type="checkbox"/>	<input type="checkbox"/>	<input type="checkbox"/>	
CHECK EXHAUST SYSTEM	<input type="checkbox"/>	<input type="checkbox"/>	<input type="checkbox"/>	
CHECK FUEL TANK	<input type="checkbox"/>	<input type="checkbox"/>	<input type="checkbox"/>	
CHECK GENERAL INSPECTION	<input type="checkbox"/>	<input type="checkbox"/>	<input type="checkbox"/>	
CHECK RUN-STOP CONTROL	<input type="checkbox"/>	<input type="checkbox"/>	<input type="checkbox"/>	
CHECK PRE-HEATER	<input type="checkbox"/>	<input type="checkbox"/>	<input type="checkbox"/>	
CHECK CONTROL PANELS	<input type="checkbox"/>	<input type="checkbox"/>	<input type="checkbox"/>	
REMOVE WATER FROM FUEL FILTER(S) AND FUEL TANK	<input type="checkbox"/>	<input type="checkbox"/>	<input type="checkbox"/>	
RUN ENGINE	<input type="checkbox"/>	<input type="checkbox"/>	<input type="checkbox"/>	
CHECK WARNING LIGHTS	<input type="checkbox"/>	<input type="checkbox"/>	<input type="checkbox"/>	
CLEAN COOLING LOOP STRAINERS	<input type="checkbox"/>	<input type="checkbox"/>	<input type="checkbox"/>	
EVERY 6 MONTHS				
CLEAN BATTERIES	<input type="checkbox"/>	<input type="checkbox"/>	<input type="checkbox"/>	
CHECK BATTERY CHARGING SYSTEM	<input type="checkbox"/>	<input type="checkbox"/>	<input type="checkbox"/>	
CHECK DIESEL ENGINE BELT TENSION	<input type="checkbox"/>	<input type="checkbox"/>	<input type="checkbox"/>	
CHECK COOLANT LEVELS	<input type="checkbox"/>	<input type="checkbox"/>	<input type="checkbox"/>	
CHECK DRIVESHAFT UNIVERSAL JOINTS	<input type="checkbox"/>	<input type="checkbox"/>	<input type="checkbox"/>	
CHECK FUEL LINES	<input type="checkbox"/>	<input type="checkbox"/>	<input type="checkbox"/>	
CUSTOMER'S REPRESENTATIVE WITNESSING MAINTENANCE:	AMERIFLO REPRESENTATIVE WITNESSING MAINTENANCE:			
NAME: _____ DATE: _____	NAME: _____	DATE: _____		

PROCEDURE	YES	NO	N/A	COMMENTS
EVERY 1 YEAR				
CLEAN AIR FILTER(S)	<input type="checkbox"/>	<input type="checkbox"/>	<input type="checkbox"/>	
CHECK COOLANT INHIBITOR	<input type="checkbox"/>	<input type="checkbox"/>	<input type="checkbox"/>	
CHECK DRIVE BELT(S) & PROPER DRIVE BELT TENSION	<input type="checkbox"/>	<input type="checkbox"/>	<input type="checkbox"/>	
CRANKCASE VENT SYSTEM	<input type="checkbox"/>	<input type="checkbox"/>	<input type="checkbox"/>	
LUBRICATE DRIVESHAFT UNIVERSAL JOINTS	<input type="checkbox"/>	<input type="checkbox"/>	<input type="checkbox"/>	
CHANGE OIL	<input type="checkbox"/>	<input type="checkbox"/>	<input type="checkbox"/>	
REPLACE FUEL AND OIL FILTERS	<input type="checkbox"/>	<input type="checkbox"/>	<input type="checkbox"/>	
CHECK HEAT EXCHANGER	<input type="checkbox"/>	<input type="checkbox"/>	<input type="checkbox"/>	
CHECK DIESEL ENGINE MOUNTING ISOLATORS	<input type="checkbox"/>	<input type="checkbox"/>	<input type="checkbox"/>	
CHECK WIRING SYSTEM	<input type="checkbox"/>	<input type="checkbox"/>	<input type="checkbox"/>	
GENERAL INSPECTION	<input type="checkbox"/>	<input type="checkbox"/>	<input type="checkbox"/>	
CHECK BATTERIES	<input type="checkbox"/>	<input type="checkbox"/>	<input type="checkbox"/>	
CHECK ENGINE OIL	<input type="checkbox"/>	<input type="checkbox"/>	<input type="checkbox"/>	
CHECK OIL FILTER	<input type="checkbox"/>	<input type="checkbox"/>	<input type="checkbox"/>	
CHECK EXHAUST SYSTEM	<input type="checkbox"/>	<input type="checkbox"/>	<input type="checkbox"/>	
CHECK FUEL TANK	<input type="checkbox"/>	<input type="checkbox"/>	<input type="checkbox"/>	
CHECK COOLING LOOP WYE-STRAINERS	<input type="checkbox"/>	<input type="checkbox"/>	<input type="checkbox"/>	
CHECK DIESEL ENGINE INSTRUMENTATION	<input type="checkbox"/>	<input type="checkbox"/>	<input type="checkbox"/>	
DIESEL ENGINE OPERATION TEST	<input type="checkbox"/>	<input type="checkbox"/>	<input type="checkbox"/>	
DIESEL ENGINE OVERSPEED TEST	<input type="checkbox"/>	<input type="checkbox"/>	<input type="checkbox"/>	
DIESEL ENGINE SHUT-DOWN INSPECTION	<input type="checkbox"/>	<input type="checkbox"/>	<input type="checkbox"/>	
VALVE CLEARANCES	<input type="checkbox"/>	<input type="checkbox"/>	<input type="checkbox"/>	
EVERY 2 YEARS				
CHECK FUEL INJECTORS	<input type="checkbox"/>	<input type="checkbox"/>	<input type="checkbox"/>	
CHECK TURBOCHARGER (IF SUPPLIED)	<input type="checkbox"/>	<input type="checkbox"/>	<input type="checkbox"/>	
REPLACE AIR FILTER(S)	<input type="checkbox"/>	<input type="checkbox"/>	<input type="checkbox"/>	
REPLACE BATTERIES	<input type="checkbox"/>	<input type="checkbox"/>	<input type="checkbox"/>	
REPLACE BELTS	<input type="checkbox"/>	<input type="checkbox"/>	<input type="checkbox"/>	
REPLACE COOLANT HOSES	<input type="checkbox"/>	<input type="checkbox"/>	<input type="checkbox"/>	
REPLACE COOLANT	<input type="checkbox"/>	<input type="checkbox"/>	<input type="checkbox"/>	
REPLACE THERMOSTAT(S)	<input type="checkbox"/>	<input type="checkbox"/>	<input type="checkbox"/>	
REMOVE DIESEL ENGINE WATER PUMP TO INSPECT IMPELLER AND MECHANICAL SEAL	<input type="checkbox"/>	<input type="checkbox"/>	<input type="checkbox"/>	
CUSTOMER'S REPRESENTATIVE WITNESSING MAINTENANCE:		AMERIFLO REPRESENTATIVE WITNESSING MAINTENANCE:		
NAME:	DATE:	NAME:	DATE:	

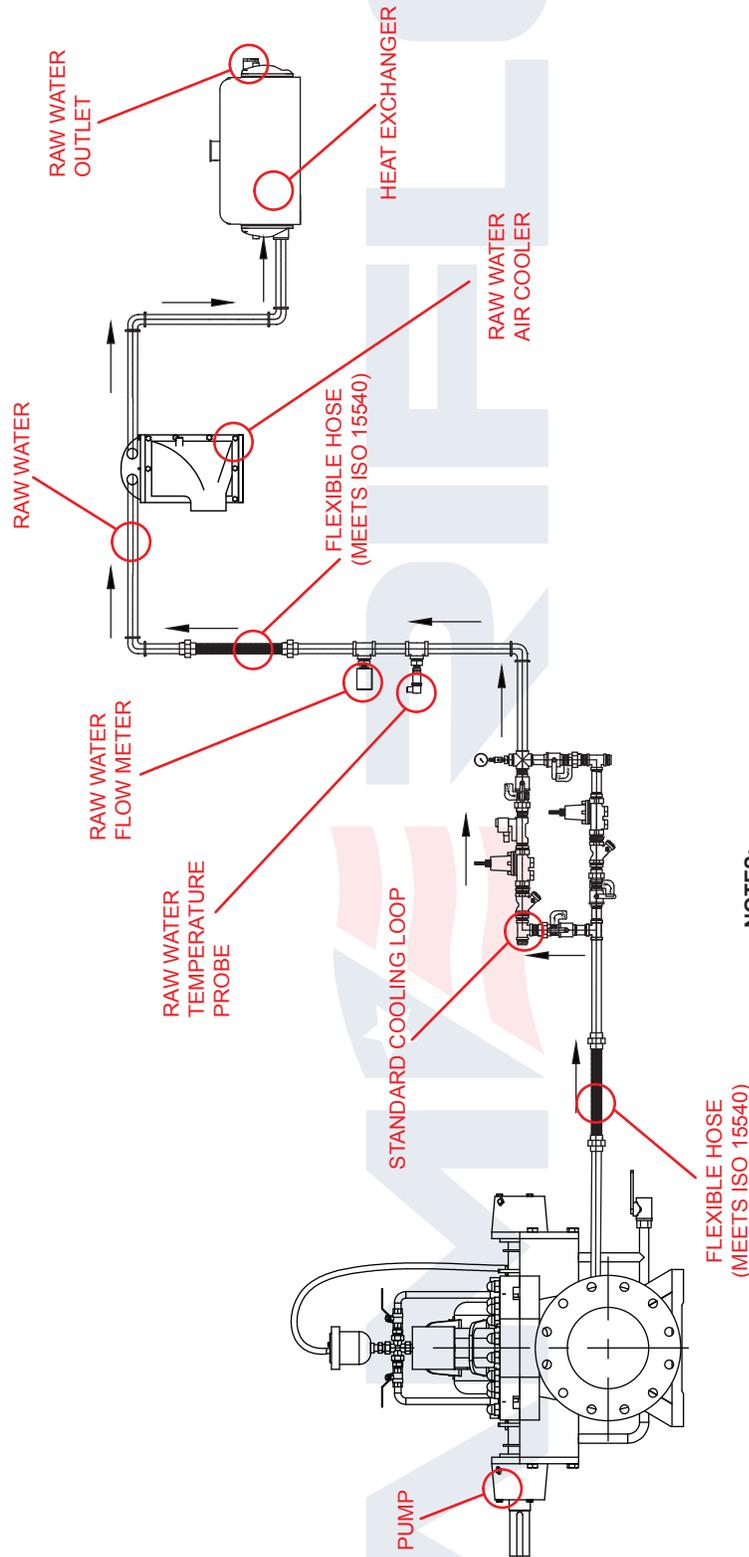

NOTES:

1. WHEN THE RAW WATER FLOW IS LESS THAN 80% OF RATED FLOW OR RAW WATER PRESSURE IS LESS THAN 80% OF RATED PRESSURE (NORMALLY 12 PSI [0.8 BAR]) THE PRESSURE SWITCH WILL SEND AN ALARM SIGNAL TO THE INSTRUMENT PANEL.
2. WHEN THE RAW WATER TEMPERATURE IS HIGHER THAN 104°F [40°C] THE TEMPERATURE SENSOR WILL SEND AN ALARM SIGNAL TO THE INSTRUMENT PANEL. THE ALARM WILL STOP WHEN THE RAW WATER TEMPERATURE DROPS BELOW 86°F [30°C].

REV	DESCRIPTION	DATE	APVD	DATE	APPROVED	DATE	MATERIAL
A	CREATION	MJF	DWN			09/01/2020	
REV	DESCRIPTION						

NAME	COOLING SYSTEM FLOW SCHEMATIC (RAW COOLER) (EXTERNAL RAW WATER)	PROJECTION:	1st Angle
DRW BY:	MJF	DATE:	09/01/2020
CHK BY:		DATE:	
PART NO.:	CSFSE-AC	SCALE:	NONE
		PAGE	1
		OF	1



NOTES:

- REFER TO THE LATEST EDITION OF NFPA 20 FOR ADDITIONAL REQUIREMENTS.
- THE FUEL SUPPLY TANK SHALL HAVE A CAPACITY OF AT LEAST 1 GALLON [5.07 LITERS] PER HP [KW] PLUS 5% FOR EXPANSION AND 5% FOR THE SUMP.
- DOWN PIPE RECOMMENDED FOR FUEL RETURN LINE TO PREVENT FOAMING OF THE FUEL WITHIN THE TANK IS TO TERMINATE IT AT ONE HALF THE TANK HEIGHT.
- DOWN PIPE RECOMMENDED FOR FUEL FILLING LINE TO PREVENT FOAMING OF THE FUEL WITHIN THE TANK IS TO TERMINATE IT AT 3 - 6 INCHES [76.2 - 152.4 MILLIMETERS] FROM THE TANK BOTTOM.
- THE ENGINE MANUFACTURER'S FUEL PUMP STATIC HEAD PRESSURE LIMITS SHALL NOT BE EXCEEDED WHEN THE LEVEL OF THE FUEL TANK IS AT ITS MAXIMUM LEVEL.
- FUEL PIPING SHALL NOT BE GALVANIZED OR COPPER MATERIAL.
- THE FUEL SUPPLY TANK SHALL BE LOCATED SO THAT THE FUEL SUPPLY PIPE CONNECTION TO THE ENGINE IS NOT LOWER THAN THE CENTERLINE OF THE ENGINE FUEL PUMP.
- THE FUEL RETURN LINE SHALL BE INSTALLED ACCORDING TO THE ENGINE MANUFACTURERS RECOMMENDATION. IN CLIMATES WHERE TEMPERATURES ARE BELOW 32°F [0°C] THE FUEL TANK MUST BE PLACED INSIDE.
- IF DIESEL #1 FUEL IS NOT AVAILABLE #2 DIESEL FUEL CAN BE USED IF AUTHORIZED BY THE ENGINE MANUFACTURER. IF #2 DIESEL FUEL IS USED, THE ENGINE NAMEPLATE MUST BE MODIFIED NOTING A DERATE IN HORSEPOWER OF 10%.
- THE GRADE OF DIESEL FUEL SHALL BE INDICATED ON THE FUEL TANK BY LETTERS THAT ARE A MINIMUM OF 6 INCHES [152 MILLIMETERS] IN HEIGHT AND IN CONTRASTING COLOR TO THE TANK.
- CONSULT THE ENGINE MANUFACTURER INSTALLATION, OPERATION & MAINTENANCE MANUAL FOR THE SPECIFIC ENGINE MODEL TO DETERMINE FUEL TANK SIZE AND MINIMUM FUEL TANK SUPPLY & RETURN LINE SIZES.

PIPING BY OTHERS

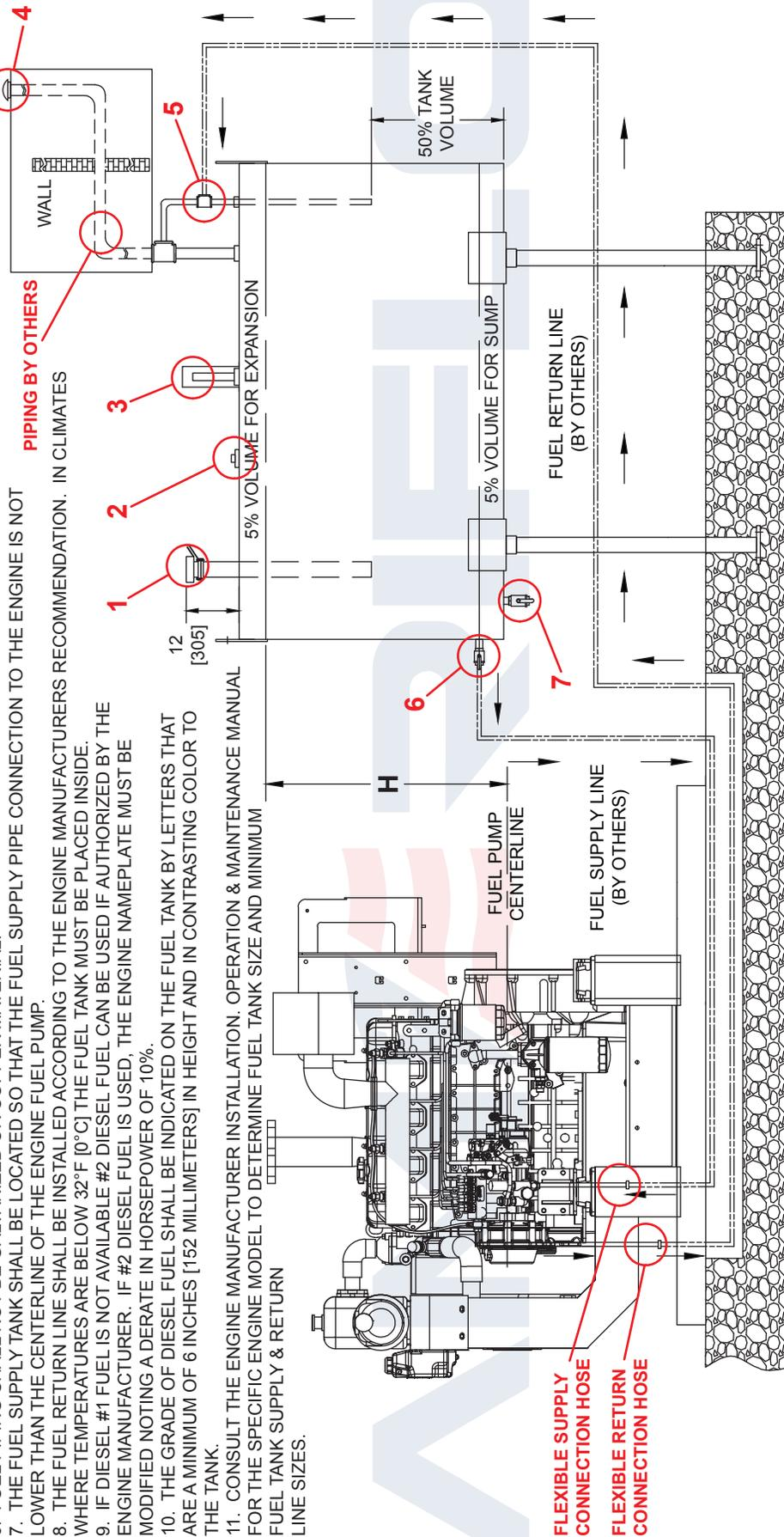

NOTES:

- MAXIMUM ALLOWABLE FUEL HEIGHT ABOVE FUEL PUMP IS 9.8 FEET [3 METERS].
- CHECK VALVE OPENING PRESSURE IS 5 PSI [34.3 KPA].

ITEM	DESCRIPTION
1	LOCKABLE FUEL CAP COMBINED WITH A REMOVABLE STRAINER (MAX. 0.06 MESH)
2	LOW FUEL LEVEL SWITCH
3	FUEL GAUGE
4	SCREENED TANK VENT
5	FUEL RETURN
6	MANUAL VALVE WITH PROVISION FOR PADLOCK
7	DRAIN BALL VALVE, 1 INCH WITH PROVISION FOR PADLOCK

REV	UNITS (in/mm)
A	

NAME: FUEL TANK & FUEL SUPPLY SYSTEM PER NFPA 20	PROJECTION:
DATE: 09/01/2020	PROJECT:
CHK BY: MJF	
DATE: 09/01/2020	
PART NO.: FTFSS-00	SCALE: NONE
MATERIAL:	PAGE: 1
	OF: 1