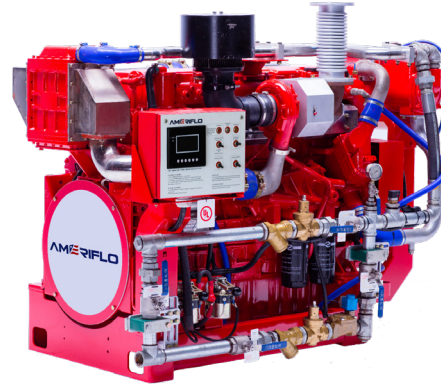

UL - cUL LISTED RATINGS BHP & KW

ENGINE MODEL:	AF6-128B
EMISSIONS:	TIER 0
DATE:	09/01/2020
DRAWING NUMBER:	AF6-1128B.00
PERFORMANCE CURVE NUMBER:	C06128B
RATED POWER:	412 BHP @ 2100 RPM 307 KW @ 2100 RPM
REFERENCE NUMBER:	14DS001E
VERSION:	A

GENERAL ENGINE DATA

TYPE:	4 CYCLE; INLINE; WATER COOLED	
NUMBER OF CYLINDERS:	6	
ASPIRATION:	TURBOCHARGED + WATER COOLED	
BORE & STROKE - IN [MM]:	5.04 x 6.02 [128 x 153]	
CYLINDER LINER TYPE:	<input checked="" type="checkbox"/> WET <input type="checkbox"/> DRY	
DISPLACEMENT - IN ³ [L]:	720 [11.8]	
COMPRESSION RATIO:	17:01	
FIRING ORDER:	1 - 5 - 3 - 6 - 2 - 4	
COMBUSTION SYSTEM:	DIRECT INJECTION	
ROTATION (AS VIEWED FROM FRONT OF ENGINE):	CCW	
VALVES PER CYLINDER:	INTAKE: 2 EXHAUST: 2	
VALVE LASH (COLD ENGINE):	INTAKE - IN [MM]:	0.016 [0.40]
	EXHAUST - IN [MM]:	0.026 [0.65]
IGNITION TYPE:	COMPRESSION (DIESEL)	
CHARGE AIR COOLING TYPE:	RAW WATER	
WEIGHT (FUEL PUMP CONFIGURATION) - LBS [KG]:	3197 [1450]	
DIMENSIONS (L x W x H) - IN [MM]:	71 x 41 x 55 [1795 x 1040 x 1405]	
FLYWHEEL / FLYWHEEL HOUSING DIMENSIONS:	14.00 / SAE #1	
TORQUE @ RATED RPM - LB-FT [N-M]:	1030 [1396]	

ENGINE PERFORMANCE DATA

ESTIMATED FREE FIELD SOUND PRESSURE LEVEL AT 3 FEET [1 METER] WITH FULL-LOAD GOVERNED SPEED (INCLUDES NOISE FROM EXHAUST, COOLING SYSTEM AND DRIVEN COMPONENTS)	dBa	≤ 108
---	-----	-------

ALL DATA IS BASED ON ENGINE OPERATING WITH FUEL SYSTEM, LUBRICATING OIL PUMP, AIR CLEANER AND ALTERNATOR. DOES NOT INCLUDE AIR COMPRESSOR, FAN & OPTIONAL EQUIPMENT. DATA IS BASED ON SAE STANDARD J1349 CONDITIONS AT 300 FEET [91.4 METERS] ALTITUDE, 29.61 INCHES [752 MILLIMETERS] HG DRY BAROMETER AND 77°F [25°C] INTAKE AIR TEMPERATURE USING #0 DIESEL FUEL FOLLOWING THE GB 252-2011 STANDARD.

ALTITUDE ABOVE WHICH OUTPUT SHOULD BE DERATED:	FEET [METER]	300 [91]
DERATE PER 1,000 FEET [305 METERS] ABOVE ALTITUDE LIMIT:	3%	
TEMPERATURE ABOVE WHICH OUTPUT SHOULD BE DERATED:	°F [°C]	77 [25]
DERATE PER 10°F [5.6°C] ABOVE TEMPERATURE LIMIT:	1%	

● ALL DATA CERTIFIED WITHIN ±5%.

EXHAUST SYSTEM

EXHAUST GAS TEMPERATURE @ MAXIMUM RATING (POWER) - °F [°C]:	≤ 1112 [600]
EXHAUST GAS FLOW @ MAXIMUM OUTPUT - CFM [M³/HR]:	1868 [3174]
MAXIMUM ALLOWABLE BACK PRESSURE - PSI [KPA]:	1.45 [10]
MINIMUM EXHAUST PIPE DIAMETER - IN [MM]:	4 [100]

AIR INTAKE SYSTEM

AIR CLEANER TYPE:	DRY TYPE, DISPOSABLE
AIR FLOW - CFM [M³/HR]:	978 [1662]
AIR INLET RESTRICTION (DIRTY) - PSI [KPA]:	≤ 0.87 [6]
AIR INLET RESTRICTION (CLEAN) - PSI [KPA]:	≤ 0.44 [3]

LUBRICATION SYSTEM

OIL CAPACITY (ENGINE ONLY) - QTS [L]:	43.3 [41]
MAXIMUM SUMP OIL TEMPERATURE - °F [°C]:	248 [120]
NORMAL OPERATING OIL PRESSURE RANGE - PSI [BAR]:	50.7 ~ 87.0 [3.5 ~ 6.0]
OIL PRESSURE @ IDLE - PSI [BAR]:	> 10.2 [0.7]

COOLING SYSTEM

COOLANT CAPACITY (ENGINE & HEAT EXCHANGER) - QTS [L]:	47.6 [45]	
THERMOSTAT RANGE:	START OPEN - °F [°C]:	185 [85]
	FULL OPEN - °F [°C]:	203 [95]
COOLANT PRESSURE MAXIMUM - PSI [BAR]:	13 [0.9]	
MAXIMUM ENGINE COOLANT TEMPERATURE - °F [°C]:	≤ 208 [98]	
ENGINE COOLANT FLOW @ FULL SPEED - GPM [M³/HR]:	189 [43]	
RAW WATER COOLING CAPACITY - GPM [M³/HR]:	88 [20]	
RAW WATER PRESSURE - PSI [BAR]:	36.3 [2.5]	
MAXIMUM RAW WATER TEMPERATURE - °F [°C]:	100 [37.8]	
RAW WATER INTAKE PIPE SIZE:	RAW WATER INLET - IN:	1.50 NPT
	RAW WATER OUTLET - IN:	2.00 NPT

HEATER SYSTEM

WATTAGE - W:	4500
VOLTAGE (AC) - V:	220

DC ELECTRICAL SYSTEM

NORMAL SYSTEM VOLTAGE - V:	24
STARTER MOTOR - HP [KW]:	10.1 [7.5]
RECOMMENDED MINIMUM BATTERY SIZE - AH:	180
COLD CRANKING AMPS @ 0°F (-18°C):	900
RESERVE CAPACITY - AMPS:	360
CHARGING ALTERNATOR OUTPUT - AMPS:	70
STARTER CRANKING AMPS, ROLLING @ 0°F (-18°C):	430
MINIMUM CRANKING SPEED REQUIRED FOR UNAIDED COLD START - RPM:	210

● ALL DATA CERTIFIED WITHIN ±5%.

FUEL SYSTEM

INJECTION PUMP:	INLINE, PLUNGER TYPE
INJECTION PUMP ADVANCE ANGLE - °:	14
MINIMUM SUPPLY LINE SIZE - IN [MM]:	0.50 [12]
MINIMUM RETURN LINE SIZE - IN [MM]:	0.50 [12]
FUEL MANAGEMENT CONTROL:	MECHANICAL
FUEL CONSUMPTION @ 2100 RPM - LB/BHP-HR [G/KW-HR]:	0.362 [220]
IDLE SPEED - RPM:	800
MAXIMUM GOVERNED SPEED - RPM:	2310
MAXIMUM ALLOWABLE FUEL HEIGHT ABOVE FUEL PUMP - FT [M]:	9.8 [3]
GOVERNED SPEED RATE - %:	≤ 10

① ALL DATA CERTIFIED WITHIN ±5%.



ENGINE MATERIALS & CONSTRUCTION

ENGINE		AIR INTAKE	
CAMSHAFT:		AIR CLEANER:	
TYPE	OVERHEAD	TYPE	DRIP PROOF
MATERIAL	CARBON STEEL	MATERIAL	PLEATED PAPER
LOCATION	IN BLOCK	COOLING SYSTEM	
DRIVE	SPUR GEAR	COOLANT HEAT EXCHANGER:	
CONNECTING RODS:		TYPE	TUBE & SHELL
TYPE	I-BEAM, FRACTURE	MATERIAL	
MATERIAL	FORGED STEEL	ELECTRODE	ZINC
CRANKSHAFT:		HEADERS	ALUMINUM
TYPE	GROUND	SHELL	ALUMINUM
MATERIAL	DUCTILE IRON	TUBES	COPPER
MAIN BEARINGS:		COOLANT PUMP:	
TYPE	PRECISION, HALF SHELL	TYPE	CENTRIFUGAL
MATERIAL	TIM ALUMINUM ALLOY	DRIVE	V-BELT
CYLINDER BLOCK:		THERMOSTAT:	
TYPE	GANTRY	TYPE	NON-BLOCKING
MATERIAL	CAST IRON	QUANTITY	1
CYLINDER HEAD:		COOLING LOOP (GALVANIZED):	
TYPE	ONE PIECE	TEES, ELBOWS, PIPE	GALVANIZED STEEL
MATERIAL	CAST IRON	BALL VALVES	BRASS
CYLINDER LINERS:		SOLENOID VALVE	BRASS
TYPE	WET LINED	PRESSURE REGULATOR	BRASS
MATERIAL	CAST IRON ALLOY	STRAINER	BRASS
PISTONS:		COOLING LOOP (316 STAINLESS STEEL):	
TYPE	TRUNK	TEES, ELBOWS, PIPE	316 STAINLESS STEEL
MATERIAL	ALUMINUM ALLOY	BALL VALVES	316 STAINLESS STEEL
PISTON PINS:		SOLENOID VALVE	316 STAINLESS STEEL
TYPE	FULL FLOATING	PRESSURE REGULATOR	316 STAINLESS STEEL
MATERIAL	ALLOY STEEL	STRAINER	316 STAINLESS STEEL
PISTON RINGS:		FUEL SYSTEM	
FIRST	DUCTILE CAST IRON	FUEL INJECTION PUMP:	
SECOND	ALLOY CAST IRON	TYPE	FULL MECHANICAL, CENTRIFUGAL
THIRD	ALLOY CAST IRON	DRIVE	GEAR DRIVEN
VALVES:		LUBRICATION SYSTEM	
TYPE	POPPET	TYPE	GEROTOR
ARRANGEMENT	OVERHEAD	DRIVE	GEAR
VALVE # PER CYLINDER	2 INTAKE, 2 EXHAUST		
OPERATING MECHANISM	MECHANICAL ROCKER ARM		
LIFTER TYPE	LARGE HEAD		

SPARE PARTS LIST

PART DESCRIPTION	QUANTITY	PART NUMBER	REMARKS
LUBRICATION SYSTEM			
OIL FILTER	2 PIECES	AF-D17-002-50+B	
OIL PRESSURE SENSOR	1 PIECE	AF-21103-OPS	
FUEL SYSTEM			
FUEL FILTER	1 PIECE	AF-S00010128+1	
INJECTION PUMP	1 PIECE	AF-S00003035+01	
FUEL SUPPLY & RETURN HOSE	1 PIECE	AF6-128B-6.1	
	1 PIECE	AF6-128B-6.2	
COOLING SYSTEM			
HEAT EXCHANGER	1 PIECE	AF-C300ZJ-HE	
COOLING LOOP	1 SET	AF-CL40SV	
COOLANT HOSE (90° ELBOW)	1 PIECE	AF-E90-60/150P4	
COOLANT HOSE (STRAIGHT REDUCER)	1 PIECE	AF-SR-60-65/100P4	
COOLING HOSE	1 PIECE	AF-8-3-700-CH	
	2 PIECES	AF-16-5-2000-CH	
WATER PUMP	1 PIECE		
RUNNING WATER TEMPERATURE SENSOR	1 PIECE	AF-00121-WTR	
STANDBY WATER TEMPERATURE SENSOR	1 PIECE	AF-00108-WTR	
THERMOSTAT	2 PIECES	AF-D22-102-05	
PREHEATER	1 PIECE	AF-FH220450065 OR AF-FH110200065 OR AF-SH110200065	
FLOW SENSOR	1 PIECE	AF-	
CONTROL SYSTEM			
STARTER	1 PIECE	AF-S00020830+01	
ALTERNATOR	1 PIECE	AF-S00016306+02	
BATTERY	2 PIECES	AF-N200	
STARTER CONTACTOR	2 PIECES	AF	
OVERSPEED SHUTDOWN	1 PIECE	AF	
SPEED SENSOR	1 PIECE	AF	
INSTRUMENT PANEL	1 SET	AF-ENL-AB-ETS/R-B	
TRANSMISSION SYSTEM			
BELT	2 PIECES	AF-S00006130	
STOP SOLENOID	1 PIECE	AF-5295568-SN	
INTAKE & EXHAUST SYSTEM			
AIR FILTER	1 PIECE	AF-S00034176+02	
TURBOCHARGER	1 PIECE	AF	

POWER CURVE

CURVE NUMBER:	C06128B	DATE:	09/01/2020
DISPLACEMENT - IN ³ [L]:	720 [11.8]	ASPIRATION:	TURBOCHARGED + WATER COOLED
POWER STANDARD:	UL	BORE & STROKE - IN [MM]:	5.04 x 6.02 [128 x 153]
NUMBER OF CYLINDERS:	6	FUEL SYSTEM:	INLINE, MECHANICAL

● ALL DATA CERTIFIED WITHIN ±5%.

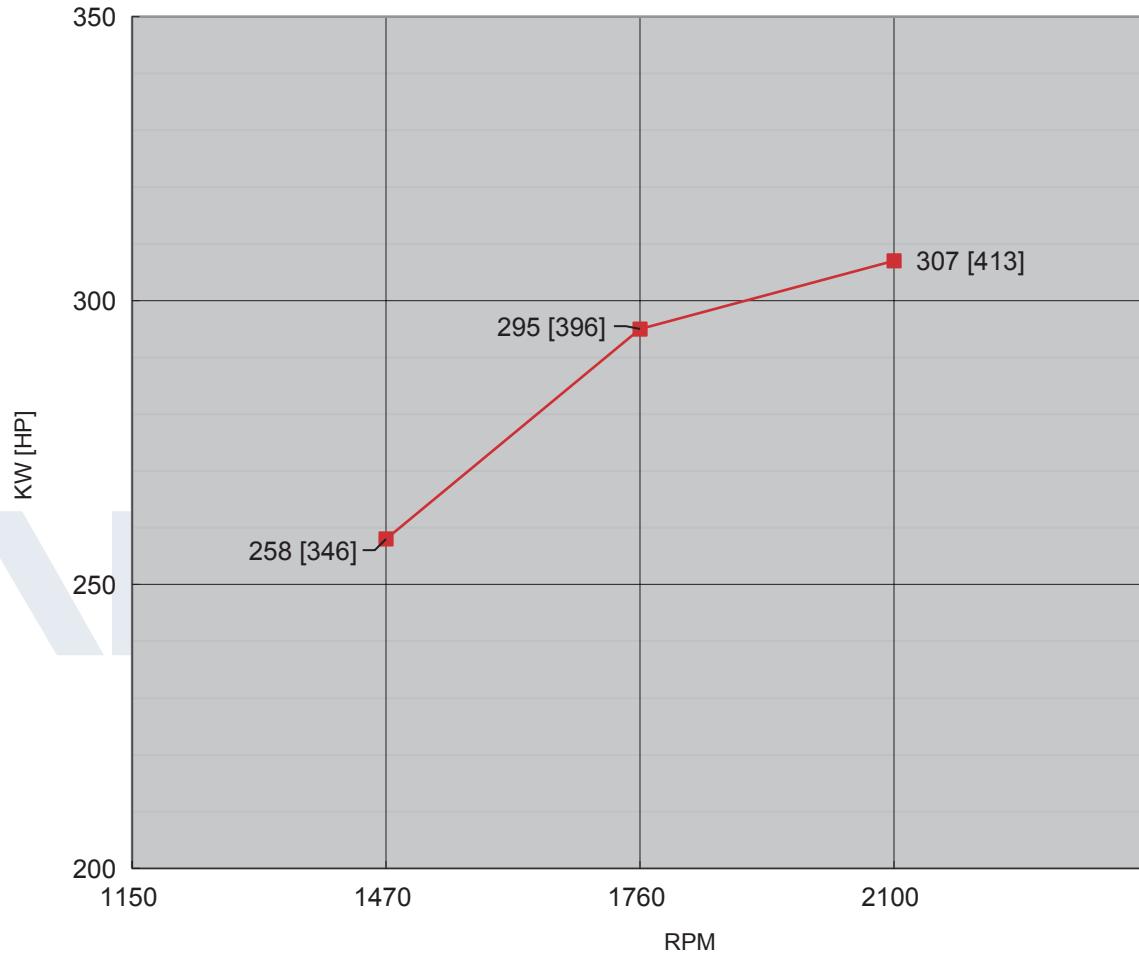

TORQUE		
SPEED	LB-FT	N-M
RPM		
1150		
1470	1236	1676
1760	1180	1601
2100	1030	1396

OUTPUT POWER		
SPEED	HP	KW
RPM		
1150		
1470	346	258
1760	396	295
2100	412	307

FUEL CONSUMPTION		
SPEED	LB/BHP-HR	G/KW-HR
RPM		
1150		
1470	0.312	190
1760	0.329	200
2100	0.362	220

● ALL DATA IS BASED ON ENGINE OPERATING WITH FUEL SYSTEM, LUBRICATING OIL PUMP, AIR CLEANER AND ALTERNATOR. DOES NOT INCLUDE AIR COMPRESSOR, FAN & OPTIONAL EQUIPMENT. DATA IS BASED ON SAE STANDARD J1394 CONDITIONS AT 300 FEET [91.4 METERS] ALTITUDE, 29.61 INCHES [752 MILLIMETERS] HG DRY BAROMETER AND 77°F [25°C] INTAKE AIR TEMPERATURE USING #0 DIESEL FUEL FOLLOWING THE GB 252-2011 STANDARD.

DATUMS:
-A — DIMENSIONAL FACE OF FLYWHEEL
-B — ENGINE HORIZONTAL CENTER (CRANKSHAFT)
-C — ENGINE VERTICAL CENTER (CRANKSHAFT)

NOTES:
 1. FUEL SUPPLY PIPING MINIMUM INSIDE DIAMETER FROM TANK TO ENGINE MUST BE ≥ 0.500 [12].
 2. FUEL RETURN PIPING MINIMUM INSIDE DIAMETER FROM TANK TO ENGINE MUST BE ≥ 0.500 [12].

DRAWING SUBJECT TO CHANGE WITHOUT NOTICE.

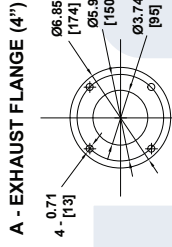
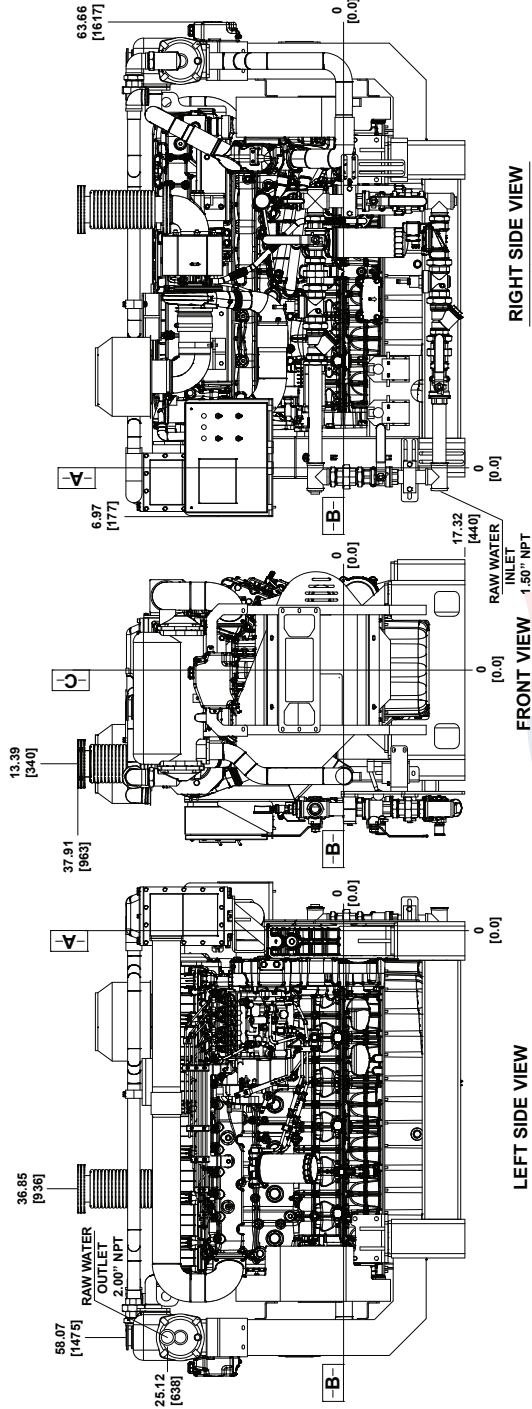

SCALE 2:1

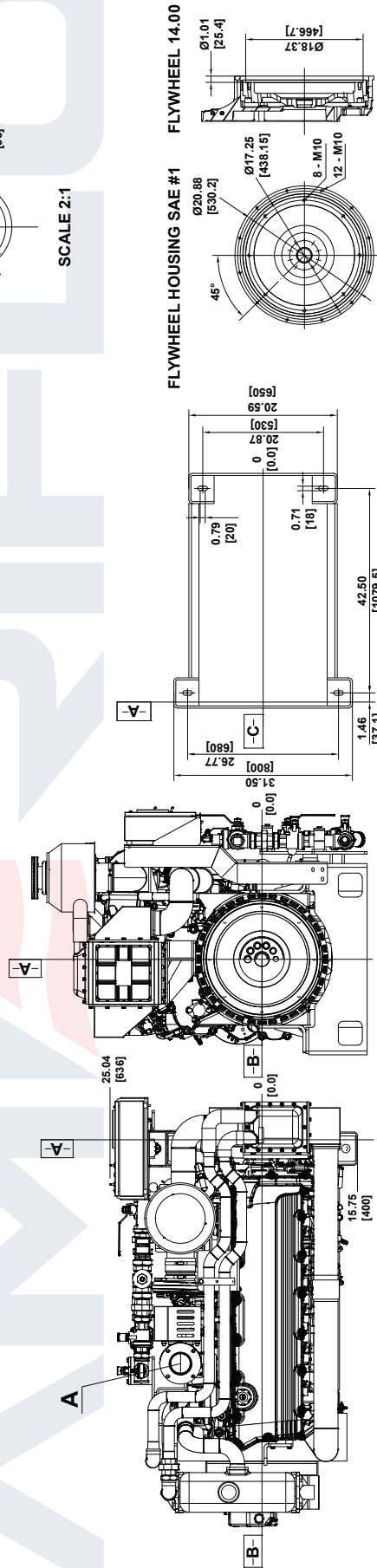

FLYWHEEL HOUSING SAE #1

FLYWHEEL 14.00

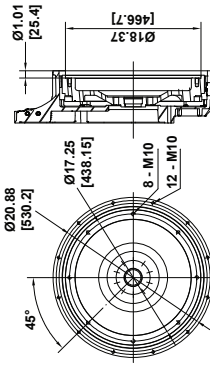

NOTES:
 1. ALL PLUMBING MUST BE SUPPORTED AND/OR ISOLATED SO THAT NO WEIGHT OR STRESS IS APPLIED TO ANY ENGINE COMPONENT.
 2. REFER TO SPECIFIC MODELS' INSTALLATION, OPERATION & MAINTENANCE MANUAL FOR INSTALLATION GUIDELINES.

REV	DESCRIPTION	DWN	APVD	DATE	APPROVED: DATE:	MATERIAL:
A	CREATION	MJF		09/01/2020	DATE:	
REV	DESCRIPTION	DWN	APVD	DATE	APPROVED: DATE:	MATERIAL:

SCALE:	PAGE:	OF
NONE	1	1

NAME:	PROJECT:
INSTALLATION DRAWING	
DIESEL FIRE PUMP DRIVER	
MODEL AF6-128B	

DATE:	DATE:
09/01/2020	

DRW BY:	CHK BY:	APPROVED:
MJF		

UNITS
IN/MM

PROJECT:



PART NO.: AF6-128B-00

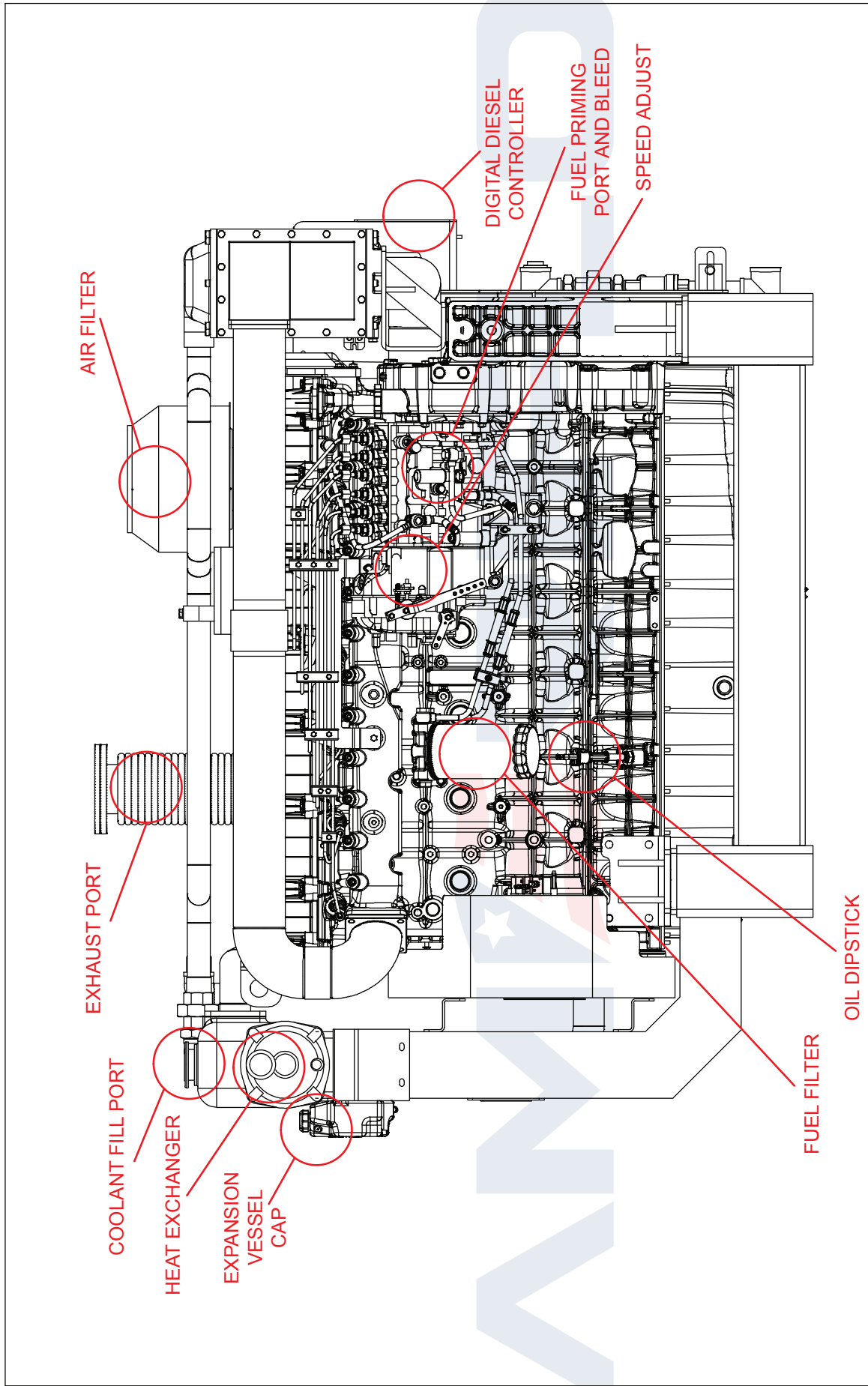

NOTES:

1. ALL PLUMBING MUST BE SUPPORTED AND/OR ISOLATED SO THAT NO WEIGHT OR STRESS IS APPLIED TO ANY ENGINE COMPONENT.
2. REFER TO SPECIFIC MODELS' INSTALLATION, OPERATION & MAINTENANCE MANUAL FOR INSTALLATION GUIDELINES.

REV	DESCRIPTION	DWN	APVD	DATE
A	CREATION	MJF		09/01/2020
REV	DESCRIPTION	DWN	APVD	DATE

AMERIFLO	PROJECTION:	DATE:	NAME:
		09/01/2020	INSTALLATION DRAWING
			DIESEL FIRE PUMP DRIVER
			MODEL AF6-128B
			PROJECT:
			PART NO.:
			AF6-128B-LEFT
			MATERIAL:
			SCALE:
			NONE
			PAGE
			1
			OF
			1

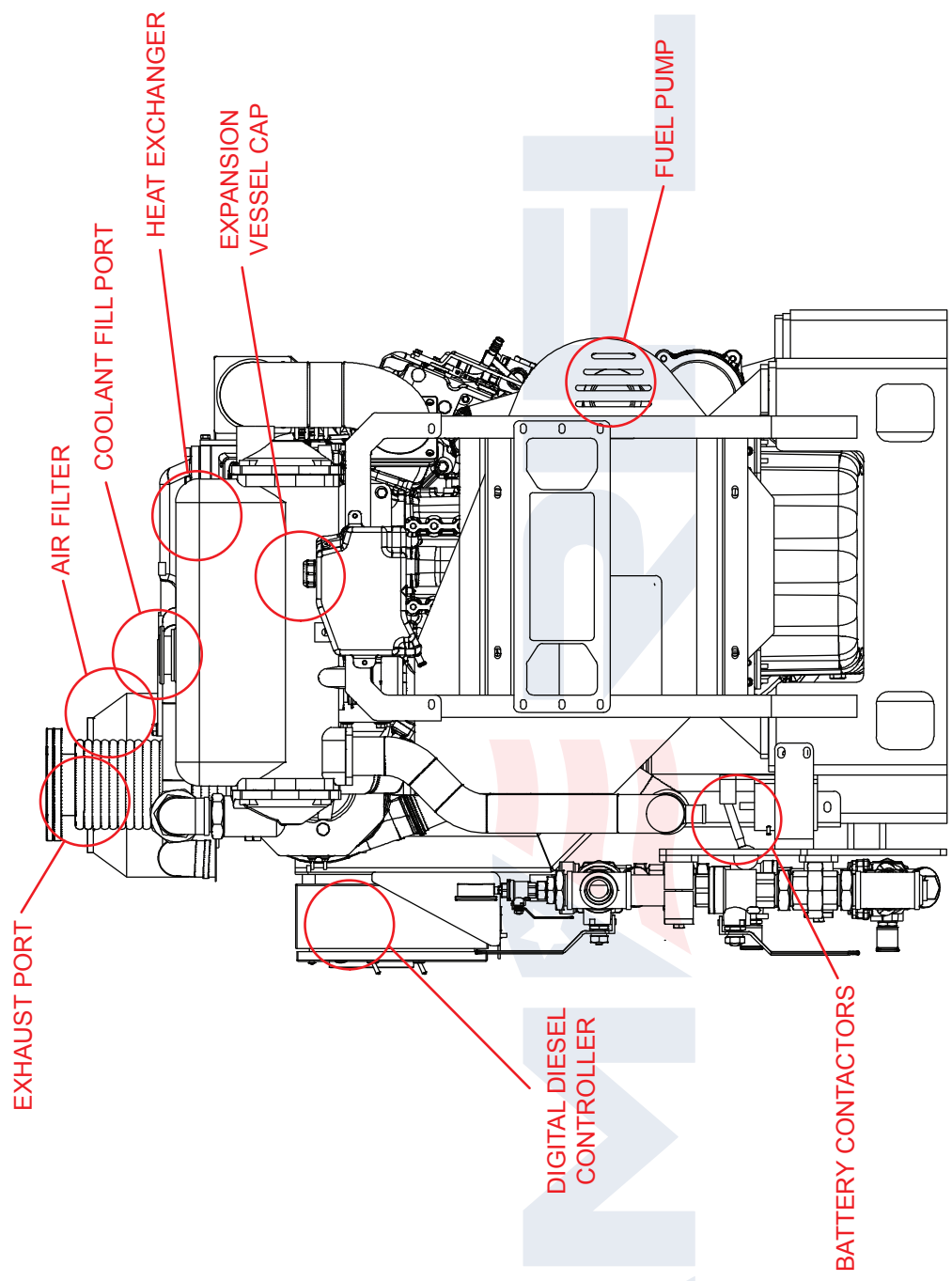

REV	UNITS	AMERIFLO	PROJECTION:	SCALE: NONE	PAGE OF	1
	IN/MM		PROJECT:			
		NAME: INSTALLATION DRAWING				
		DATE: 09/01/2020				
		DRW BY: MJF				
		NAME: DIESEL FIRE PUMP DRIVER				
		DATE: 09/01/2020				
		CHK BY: MJF				
		MODEL AF6-128B				
		PART NO.: AF6-128B-FRONT				
		APPROVED: DATE:				
		DATE: 09/01/2020				
		DESCRIPTION	DWN	APVD		
A		CREATION	MJF			
REV						

NOTES:

1. ALL PLUMBING MUST BE SUPPORTED AND/OR ISOLATED SO THAT NO WEIGHT OR STRESS IS APPLIED TO ANY ENGINE COMPONENT.
2. REFER TO SPECIFIC MODELS' INSTALLATION, OPERATION & MAINTENANCE MANUAL FOR INSTALLATION GUIDELINES.

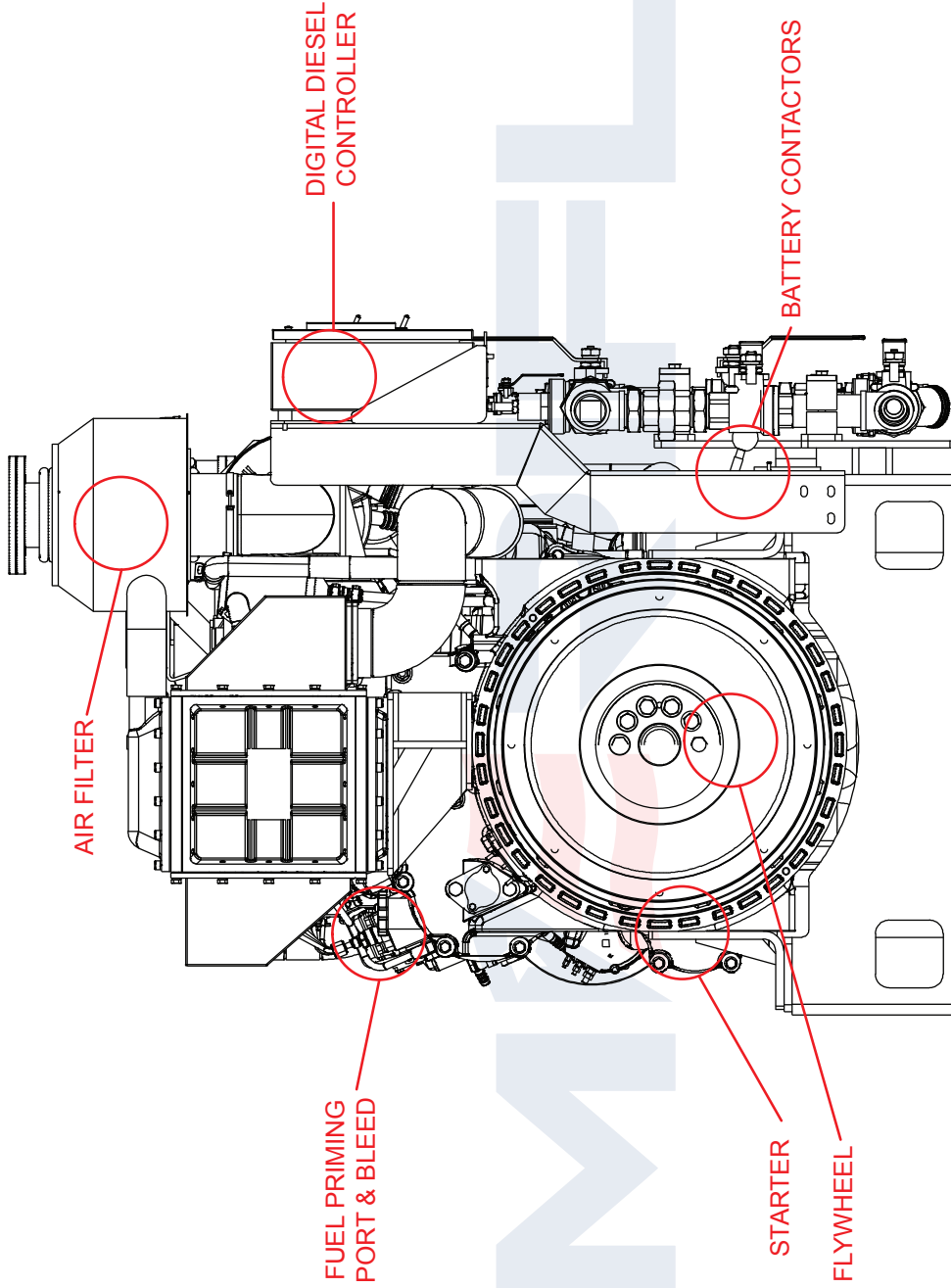

REV	UNITS	AMERIFLO	PROJECT:	SCALE: NONE	PAGE 1	OF 1
	IN/MM					
		NAME: INSTALLATION DRAWING DIESEL FIRE PUMP DRIVER MODEL AF6-128B	PROJECT:	SCALE: NONE	PAGE 1	OF 1
		DATE: 09/01/2020				
		DRW BY: MJF	APPROVED: DATE:			
		CHK BY:	DATE: 09/01/2020			
A		CREATION	DESCRIPTION	DWN	APVD	DATE
REV						

NOTES:
 1. ALL PLUMBING MUST BE SUPPORTED AND/OR ISOLATED SO THAT NO WEIGHT OR STRESS IS APPLIED TO ANY ENGINE COMPONENT.
 2. REFER TO SPECIFIC MODELS' INSTALLATION, OPERATION & MAINTENANCE MANUAL FOR INSTALLATION GUIDELINES.